



Clean Burn Recycling Centers



The Complete Package

When used in combination with a Clean Burn furnace, a state-of-the-art Clean Burn Recycling Center is the ideal system for collecting, storing and generating heat recovered from used oils. The Clean Burn Recycling Center works with most Clean Burn used-oil furnace models and provides a 250 gallon storage tank.

A Clean Burn Recycling Center makes oil handling and free heat generation easier because it combines the tank and furnace in one convenient unit.

In addition to a Clean Burn furnace and all its components, the industrial grade Clean Burn Recycling Center includes a used oil storage tank, legs, supports, brackets, mounting plates and wiring harnesses.

Your Clean Burn Distributor is a qualified expert in system selection, installation and service, and will make sure you get the system that is perfect for your facility.

- Designed from the ground up as a complete, self-contained heating and recycling system for used oils, including crankcase, ATF and hydraulic oils
- Accommodates most Clean Burn furnaces
- UL listed 250 gallon workbench tank
-

Simplifies furnace installation

- Optional funnel kit and filter drain rack kit

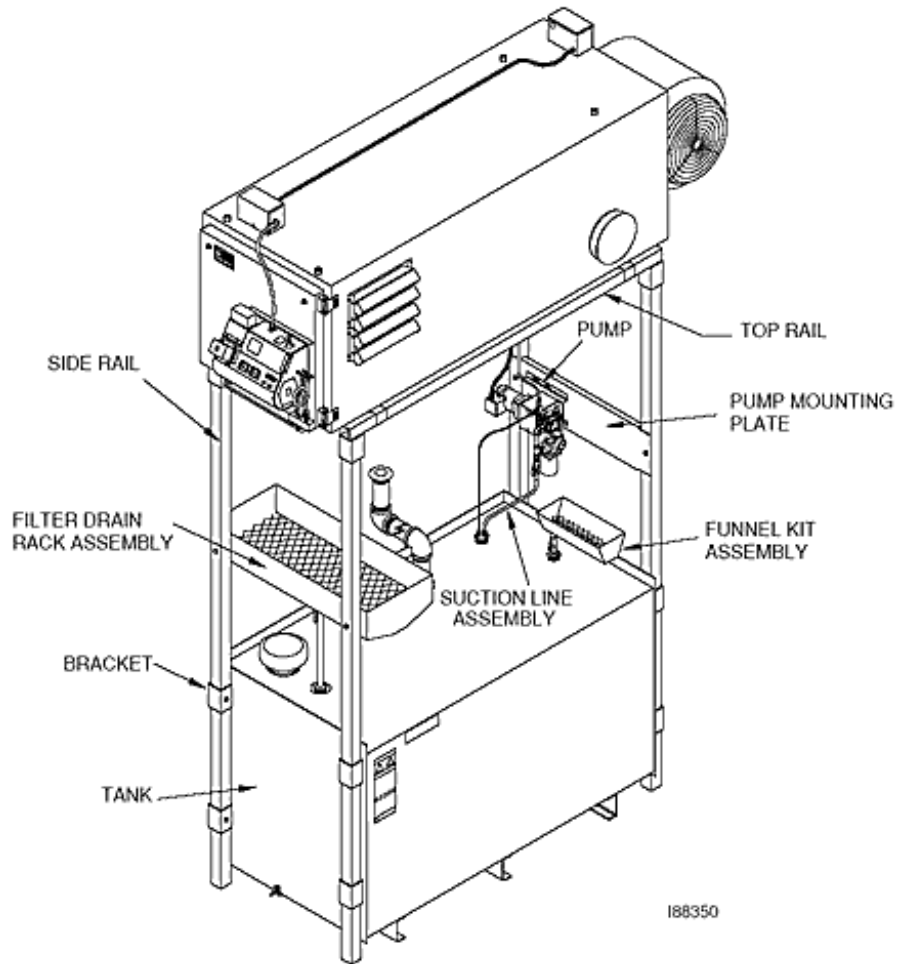

**Ecological Solutions - Lafayette, IN - toll free 1-(800)-765-3345 - (765)-449-0113
- 2005 Ecological Solutions -**