

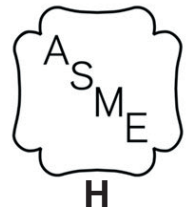

Heating Systems

OWNER'S MANUAL

CE-340 Multi-Oil Boiler
With CE-4 Burner

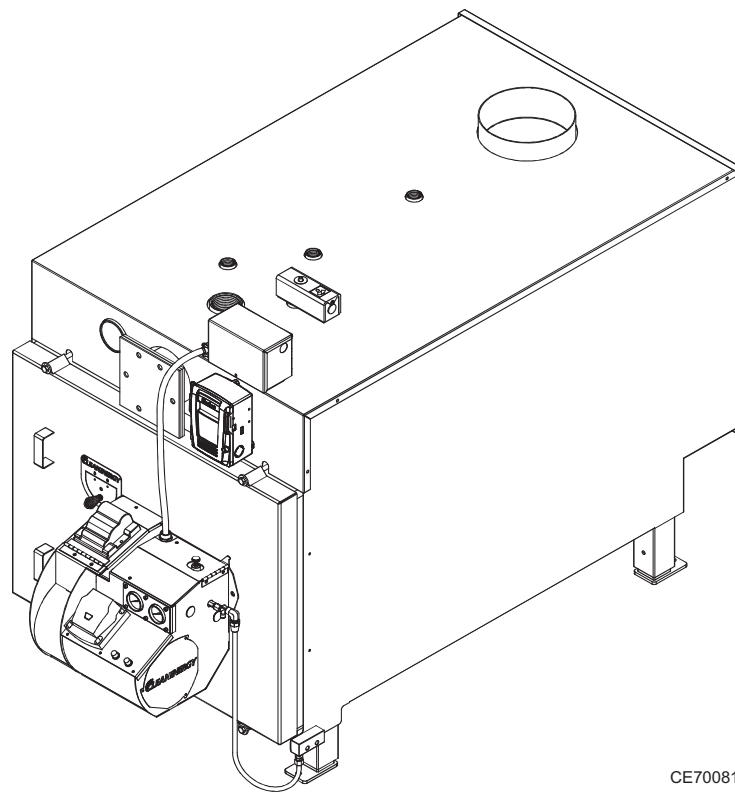

CE70081

Clean Energy Heating Systems, LLC
540 Maple Street, Honey Brook, PA 19344
www.CleanEnergyHeatingSystems.com
(888) 519-2347



WARNING: For your safety - DO NOT store gasoline or other flammable vapors and liquids in the vicinity of this or any appliance.

TABLE OF CONTENTS

SAFETY CONSIDERATIONS AND GUIDELINES.....	4
REMOVING ITEMS FROM THE COMBUSTION CHAMBER.....	6
MOVING THE BOILER INTO POSITION	7
BOILER ASSEMBLY.....	7
(1) Installing the combustion chamber sleeve.....	8
(2) Installing the burner.....	9
(3) Installing the connector block and oil line.....	10
BOILER INSTALLATION.....	11
(1) Selecting a location.....	12
(2) Mounting the boiler in position.....	13
(3) Connecting the electrical supply.....	13
(4) Installing the chimney components.....	14
(5) Oil storage tank set up	17
(6) Installing the metering pump and oil lines.....	17
(7) Connecting the compressed air line.....	22
(8) Installing the wall thermostat.....	22
(9) Disign and Installation of the Hydronics System.....	23
(10) Inspecting the Boiler Installation.....	25
BOILER CONTROLS AND SAFETY COMPONENTS.....	26
PREPARING THE METERING PUMP FOR START UP.....	26
STARTING AND ADJUSTING THE BURNER.....	27
(1) Preparing the burner for start up.....	27
(2) Priming the oil pump.....	27
(3) Adjusting the Burner.....	27
RESETTING THE OIL PRIMARY CONTROL.....	28
SETTING THE DRAFT.....	29
MAINTENANCE.....	30
SEQUENCE OF OPERATION.....	34
BOILER DIMENSIONS.....	35
WIRE DIAGRAMS.....	36
PARTS DIAGRAMS.....	38
CHIMNEY INSTALLATION DIAGRAMS.....	48
SERVICE RECORDS.....	50
APPENDIX A	51
(1) Alternate Controls.....	51
(2) Domestic Hot Water Coil Installation.....	52
WARRANTY INFORMATION.....	53

SAFETY CONSIDERATIONS AND GUIDELINES

HAZARD DEFINITIONS:

NOTICE: Intended to clarify or bring special attention to previous information.



CAUTION: Indicates a hazardous situation, which can result in minor or moderate personal injury if not avoided.



WARNING: Indicates a hazardous situation, which can result in death or serious personal injury if not avoided.



DANGER: Indicates a hazardous situation, which will result in death or serious personal injury if not avoided.

SAFETY CONSIDERATIONS:



WARNING: Incorrect installation, adjustment, or misuse of this heating equipment could result in death, severe personal injury, or substantial property damage.

To the Equipment Owner:

- Read and understand all instructions provided in this manual
- Installation and service must be completed by qualified personnel who are familiar with oil-fired appliances.
- Save this manual for future reference.

To the Professional, Qualified Installer or Service Agency:

- Read and carefully follow all instructions provided in this manual before installing, starting, or servicing this heating equipment.
- All installations must be made in accordance with state and local codes having jurisdiction.



DANGER: DO NOT store or use gasoline or other flammable/explosive liquids/vapors in or around the boiler.



DANGER: DO NOT operate the boiler if excess oil, oil vapors, or fumes have accumulated in or around the boiler.



DANGER: Improper installation, operation, or maintenance of the boiler may create a fire or explosion hazard.



WARNING: DO NOT mix unapproved substances to the used oil supply, such as:

- Anti-Freeze
- Carburetor Cleaner
- Paint Thinner
- Parts Washer and/or Solvents
- Gasoline
- Oil Additives
- Chlorinated solvents
- Any other inappropriate / hazardous material

Instruct your personnel **NEVER** to add unapproved substances to your used oil.

Burning any unapproved substance will immediately **void the boiler warranty** and may cause damage and unsafe operating conditions.



WARNING: Unauthorized boiler modifications may cause damage and unsafe operating conditions.

SAFETY CONSIDERATIONS AND GUIDELINES



WARNING: The CE-4 Burner is only approved for use on heating equipment manufactured by Clean Energy Heating Systems. The boiler is only approved for use with the CE-4 burner manufactured by Clean Energy Heating Systems.



WARNING: The installation, operation, and maintenance of this equipment in the United States must be done by qualified personnel according to instructions in the Clean Energy Heating Systems Owner's Manual and in accordance with all national, state, and local codes or authorities having jurisdiction and the following standards:

ASME Section IV	Boiler Code for Pressure Vessels
ASME CSD-1	Controls and Safety Devices for Automatically Fired Boilers
NFPA 30	Flammable and Combustible Liquids Code
NFPA 30A	Automotive and Marine Service Station Code
NFPA 31	Installation of Oil Burning Equipment
NFPA 70	National Electrical Code
NFPA 88A	Parking Structures
NFPA 88B	Repair Garages
NFPA 211	Chimney's, Fireplaces, Vents and Solid Fuel Burning Appliances

Likewise, the installation, operation, and maintenance of this equipment in Canada must be done by qualified personnel according to instructions in the Clean Energy Heating Systems Owner's Manual and in accordance with all regulations and authorities having jurisdiction and the following CSA Standards:

B139	Installatin Code for Oil Burning Equipment
B140.0	General Requirements for Oil Burning Equipment
B140.7.2	Oil Fired Steam and Hot Water Boilers for Commercial and Industrial Use
B214	Installation Code for Hydronic Heating Systems
C22.1	Canadian Electrical Code, Part 1

GUIDELINES FOR BOILER USE:

- This boiler is for industrial and/or commercial use only. This boiler is not intended for residential use.
- Clean Energy Heating Systems boilers are listed with Underwriters Laboratories (UL) in the U.S. and Canada to burn the following fuels:
 - #2 fuel oil
 - Used crankcase oil up to 50 SAE
 - Used hydraulic oil
 - Used automatic transmission fluid (U.S.)
- The EPA regulations for burning used oil are as follows:
 - Your supply of used oil is generated on-site. You may also collect oil from "do-it-yourself" oil changers.
 - Do not mix hazardous wastes, such as chlorinated solvents, with your used oil.
 - The exhaust gases of the heating equipment must be vented to the outside with an appropriate stack system.
 - The boiler is used to recycle used oil for "heat recovery". The boiler is not to be used in warm weather just to dispose of used oil.
- Only trained authorized personnel should service and maintain the boiler. Be sure the boiler receives annual maintenance to ensure safe and efficient operation.

SAFETY CONSIDERATIONS AND GUIDELINES

ADDITIONAL GUIDELINES FOR CANADIAN INSTALLATIONS:

NOTICE: This appliance has been evaluated to electrical and fuel-burning requirements only.

- (1) The installation, including stack height requirements and distance from property lines, shall be in accordance with the authorities having jurisdiction concerning environmental quality, as well as fuel, fire, and electrical safety and Table 7 in CSA B140.0-03.
- (2) The structure in which the boiler is housed shall be no less than 4.6 m (15 ft) high at the point where the boiler is situated and have a minimum length and width of 6 m (20 ft) and a minimum floor area of 37 m² (400 ft²).
- (3) Every month, the fire side of the heat exchanger and flue piping must be cleaned.
- (4) Every month, the oil-feed reservoir must be cleaned.
- (5) Every year, the exhaust stack must be cleaned.
- (6) Whenever any cleaning, including that of the flue piping and exhaust stack, is done, proper protective clothing including gloves and a face mask or respirator must be worn.
- (7) Keep the fuel valve nearest to the supply tank shut off when the burner is shut off for extended periods.



CAUTION: Used oils contain heavy metallic compounds and foreign materials. When burned, these compounds are emitted from or deposited within this heating appliance and therefore care should be taken when using, cleaning and maintaining this equipment.

GUIDELINES FOR USED OIL TANKS:



WARNING: To avoid serious injury or death, only store the following substances in the oil supply tank:

- (1) Used Crankcase Oil
- (2) Used Automatic Transmission Fluid (ATF)
- (3) Used Hydraulic Oil
- (4) #2 Fuel Oil (Diesel Fuel)

DO NOT put flammable or corrosive substances such as gasoline, chlorinated solvents, paint thinner, or any other unsafe substance in the oil supply tank.



WARNING: Waste oil may contain gasoline. Take precaution when handling and storing waste oil.



WARNING: To avoid serious injury or death, do not weld or allow open flames within 35 feet of the used oil supply tank.

- (1) The tank installation must comply with NFPA 30 and NFPA 31 fire codes.
- (2) The tank should be installed on a slight slope with a drain on the low end to allow sludge and water to be removed from the bottom of the tank.
- (3) All oil lines must be constructed of copper, steel, or brass components. DO NOT use rubber, plastic, or any other inappropriate material for oil lines.
- (4) Be sure to follow all instructions for tank installation in the Owner's Manual.

REMOVING ITEMS FROM THE COMBUSTION CHAMBER

- (1) Remove the four nuts from the front door.
- (2) Carefully swing the front door open.
- (3) Remove the items packed inside the combustion chamber.
- (4) Leave the door open to install the combustion chamber sleeve as instructed later in this manual.

MOVING THE BOILER INTO POSITION



WARNING: Because of the weight and size, take extreme care when moving the boiler.

- (1) Refer to Figure 1.
- (2) There are two angles 24" apart to allow for easy lifting.
- (3) The boiler can be lifted from either side with a forklift or pallet truck.
- (4) The boiler can also be lifted from either the front or back. The legs are spaced 27" apart which allows the use of a standard pallet truck.

NOTICE: To reduce the chance of damage, move the boiler into position before installing the burner.

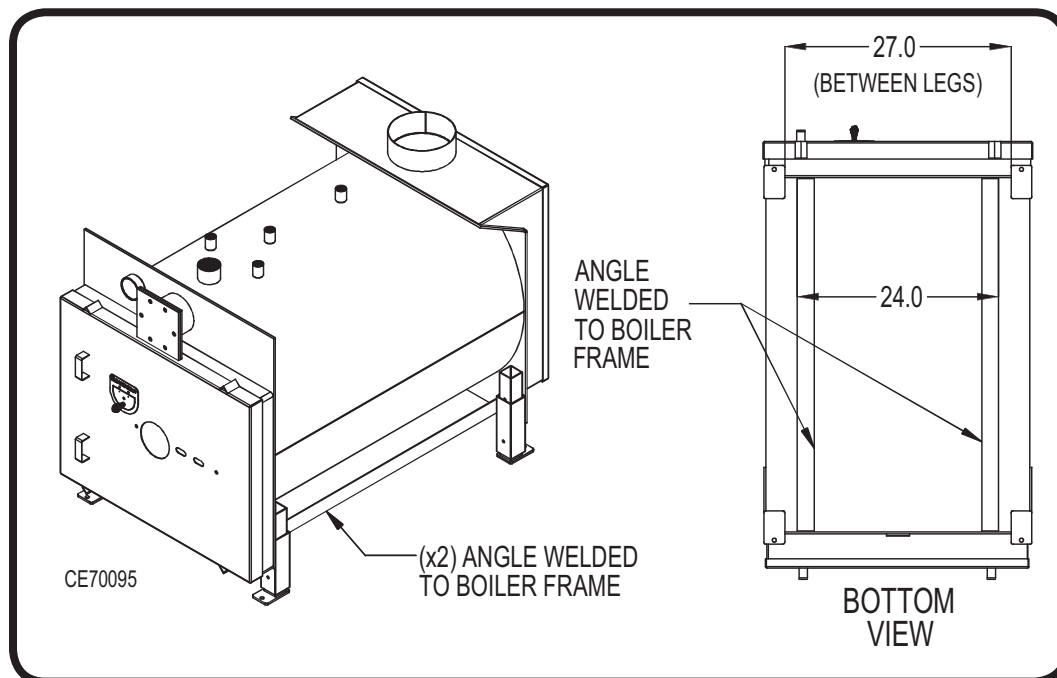

Figure 1: Boiler Shown Without Shrouding To Reveal Lifting Points

BOILER ASSEMBLY

Follow the steps below for boiler assembly (refer to Figure 2):

- (1) Install the combustion chamber *sleeve*
- (2) Install the *burner*
- (3) Install the *connector block* and *oil line*

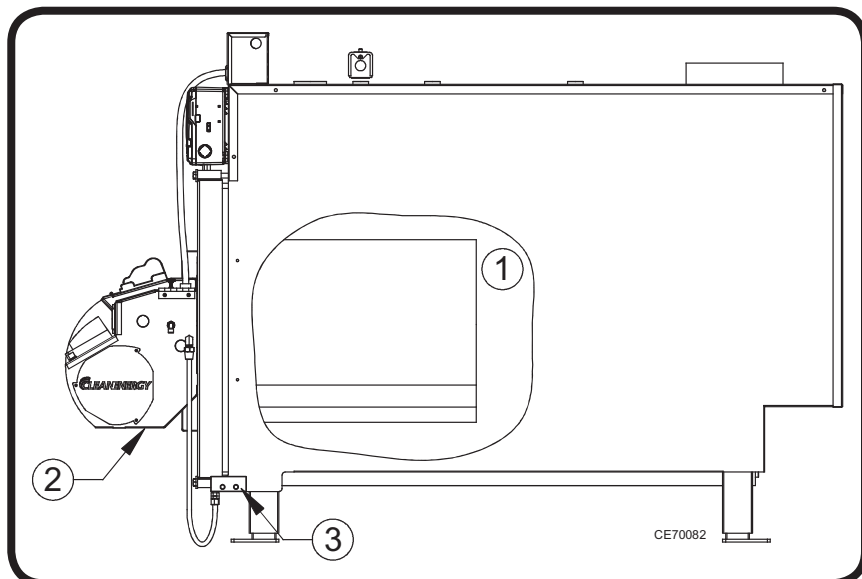

Figure 2: Typical Boiler Assembly

BOILER ASSEMBLY

Installing the Combustion Chamber Sleeve:

NOTICE: Improper combustion may occur if the boiler is used with a damaged or missing combustion sleeve. Inspect the combustion sleeve regularly for proper positioning and wear.

- (1) Refer to Figures 3 and 4 to view the proper position of the combustion chamber sleeve.
- (2) Open the front door of the boiler by loosening the four bolts and swinging the door open.
- (3) Place the 3"x3"x20" support blocks on the bottom of the combustion chamber as shown.
- (4) Place the combustion chamber sleeve on top of the support blocks and flush with the front door.
- (5) Close the front door and secure the four bolts.

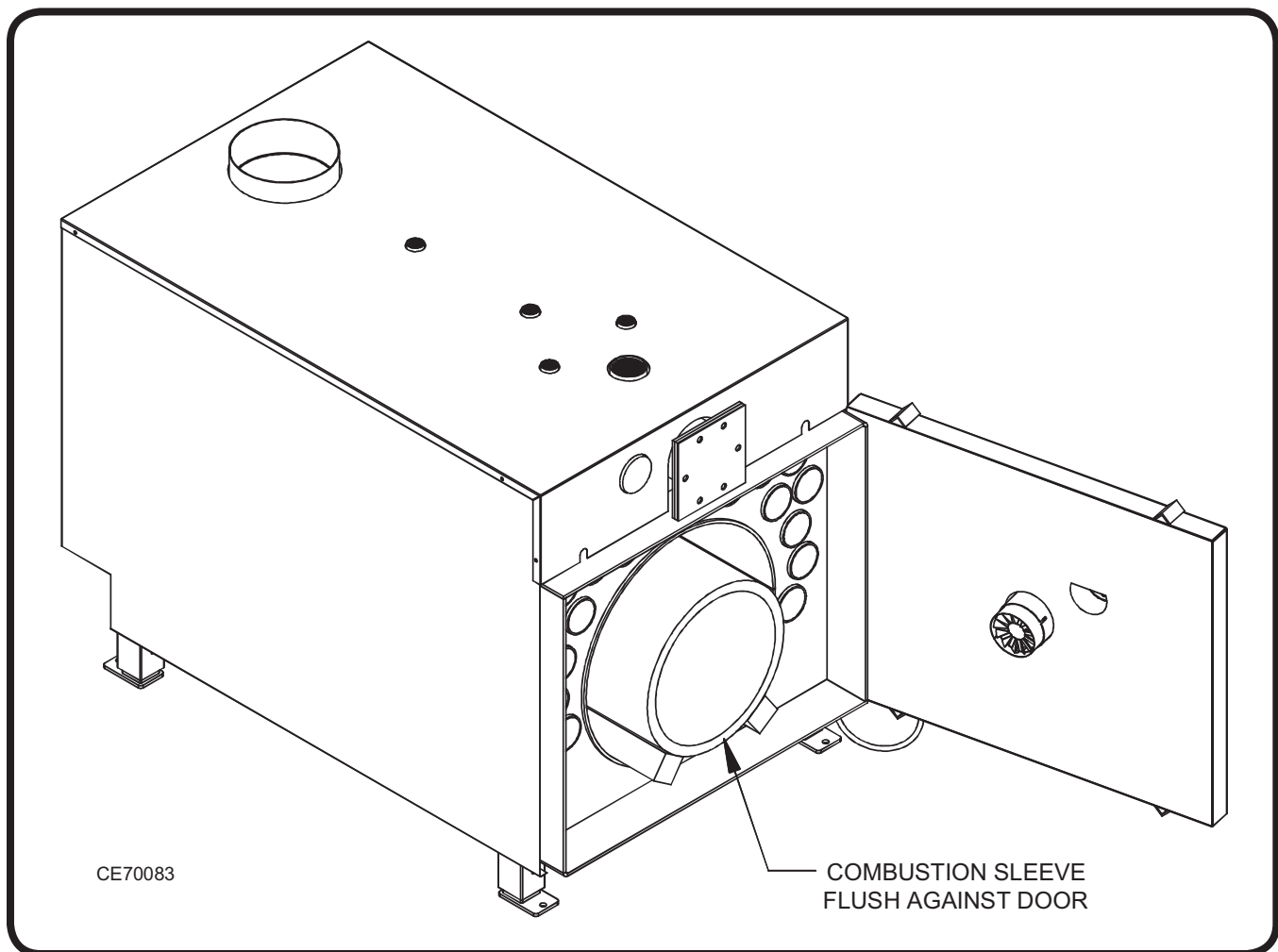

Figure 3: Proper Position of the Combustion Chamber Sleeve

BOILER ASSEMBLY

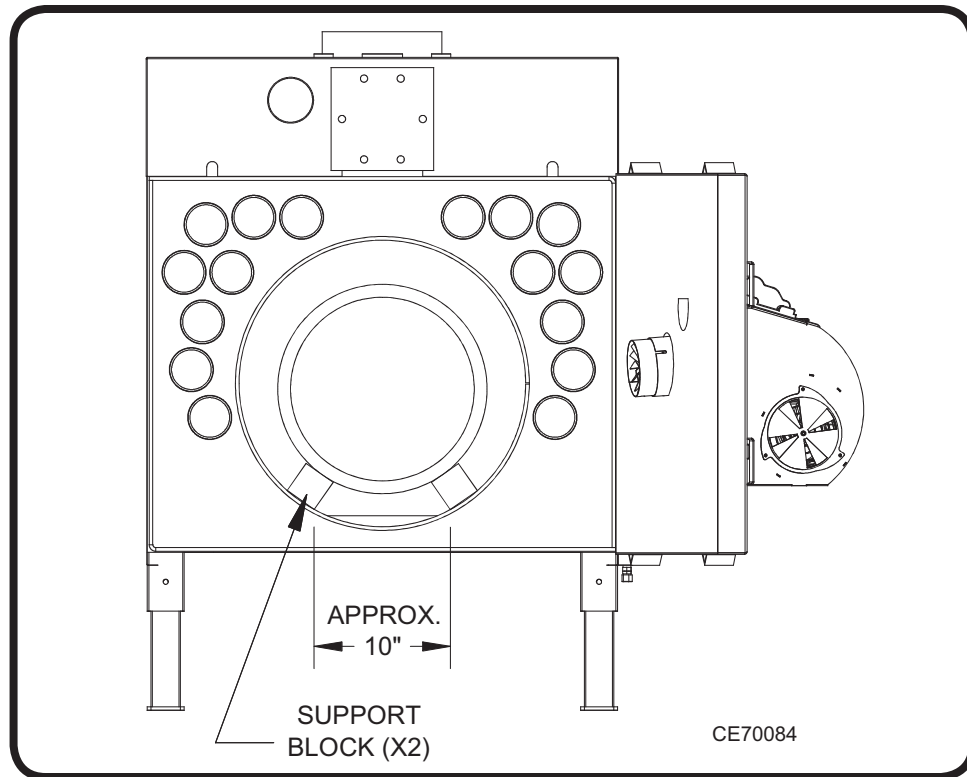

Figure 4: Combustion Chamber Sleeve Location

Installing the Burner:

NOTICE: The nozzle, electrode, and retention head may need adjustment after shipping and installation. The nozzle should remain centered in the retention head. Refer to Figure 5 for proper dimensions.

- (1) Remove the two serrated flange nuts from the front door.
- (2) Slide the blast tube of the burner through the throat of the front door.
- (3) Fasten the burner to the front door by tightening the two serrated flange nuts.

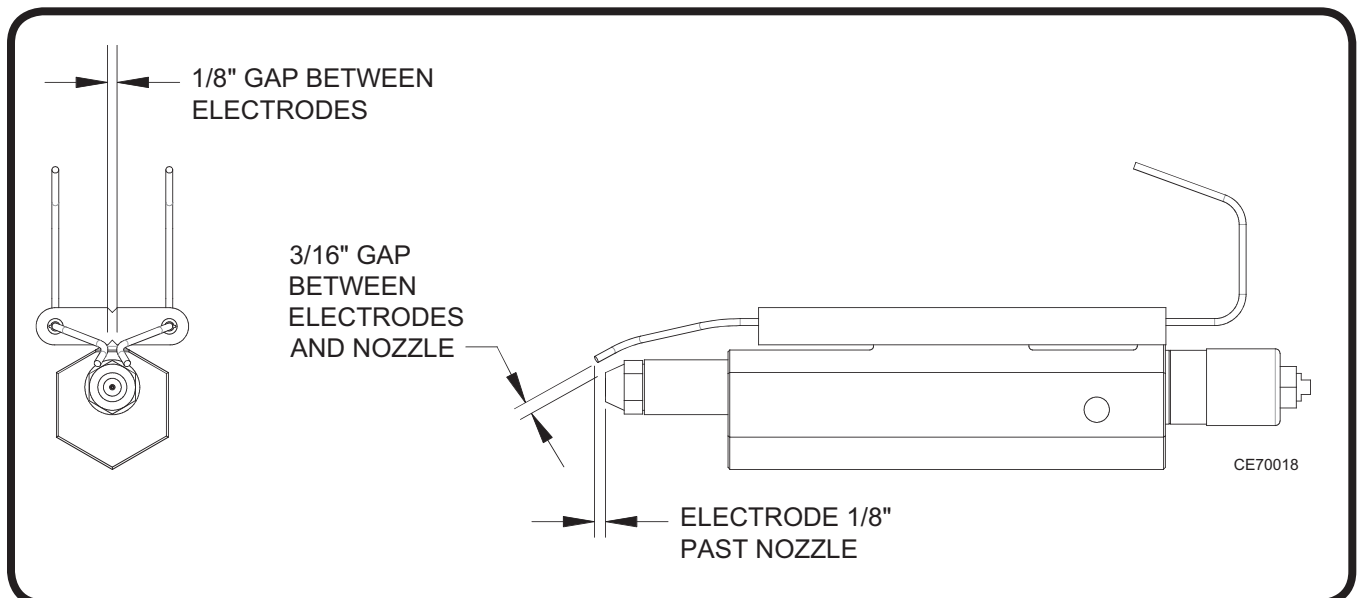

Figure 5: Nozzle and Electrode Settings

BOILER ASSEMBLY



WARNING: To prevent the risk of electrical shock, shut OFF main power to the boiler before connecting or disconnecting the burner power cord.

- (4) Refer to Figure 6
- (5) Line up the key in the receptacle with the slot in the cord.
- (6) Tighten the electrical cord when in position.

NOTICE: Make sure the plug and receptacle are properly aligned. The ground prong in the receptacle is longer than the other prongs and must be lined up properly.

Installing the Connector Block and Oil Line:

- (1) Refer to Figure 7 to position the connector block.
- (2) Fasten the connector block to the side of the boiler with the bolts provided.
- (3) Install the supplied 3/8" copper tubing from the swivel fitting in the connector block to the burner.

NOTICE: The connector block with the swivel fitting must be used to allow the front door to swing open properly. If the connector block is not used the oil line will need to be disconnected before the door is opened.

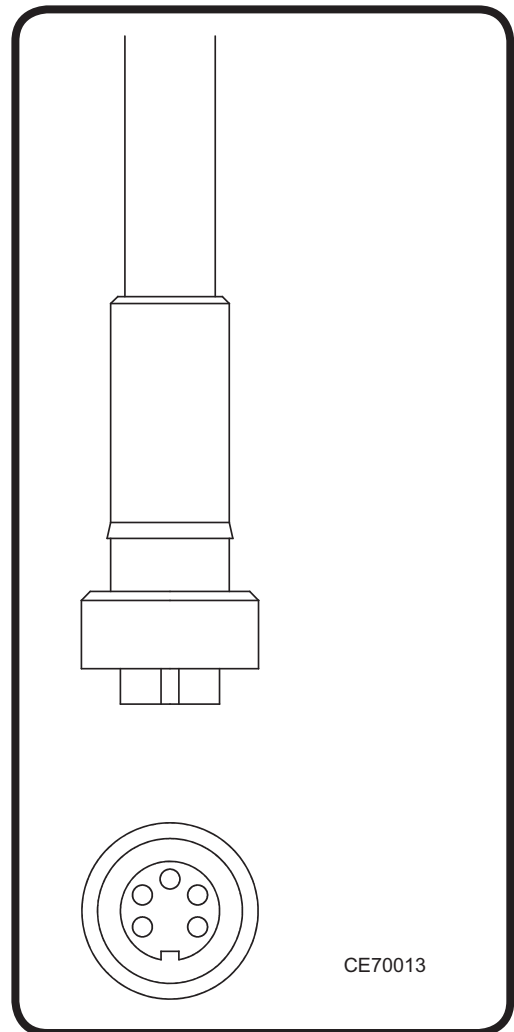

Figure 6: Installing the Burner Cord

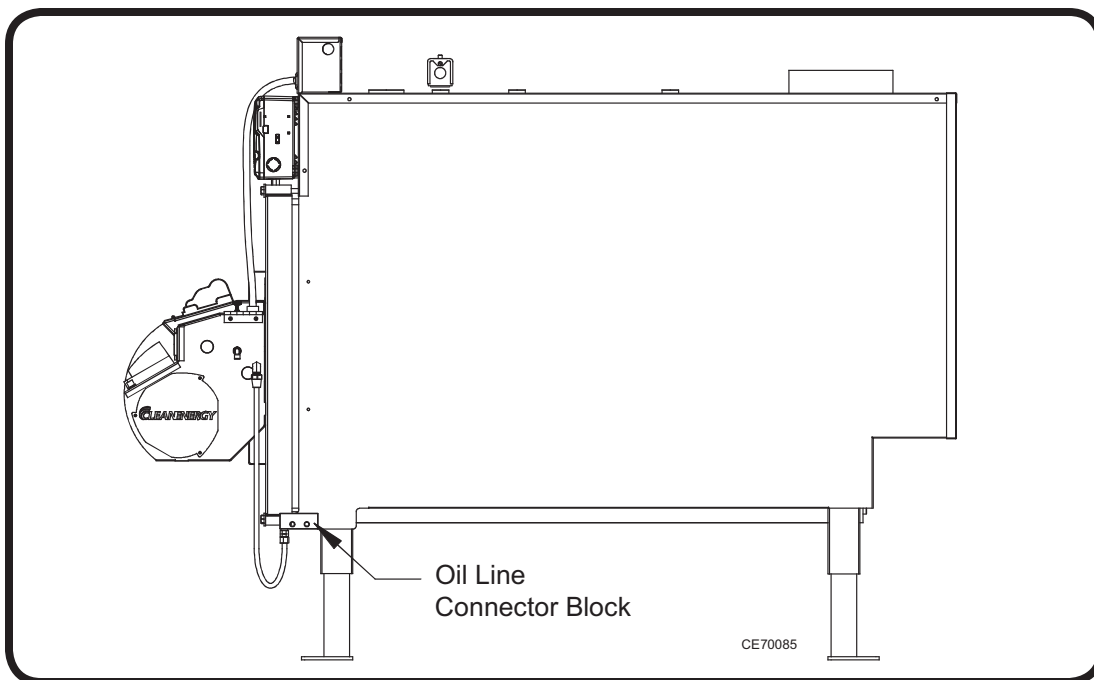

Figure 7: Installing the Connector Block and Oil Line

BOILER INSTALLATION

Refer to Figure 8 for a typical boiler installation illustration.

Installation of your boiler will include the following steps:

- (1) Selecting a location
- (2) Mounting the boiler in position
- (3) Connecting the electrical supply
- (4) Installing the chimney components
- (5) Positioning the oil storage tank
- (6) Installing the metering pump and oil lines
- (7) Connecting the compressed air line
- (8) Installing the wall thermostat
- (9) Design and Installation of hydronics system
- (10) Inspecting the boiler installation

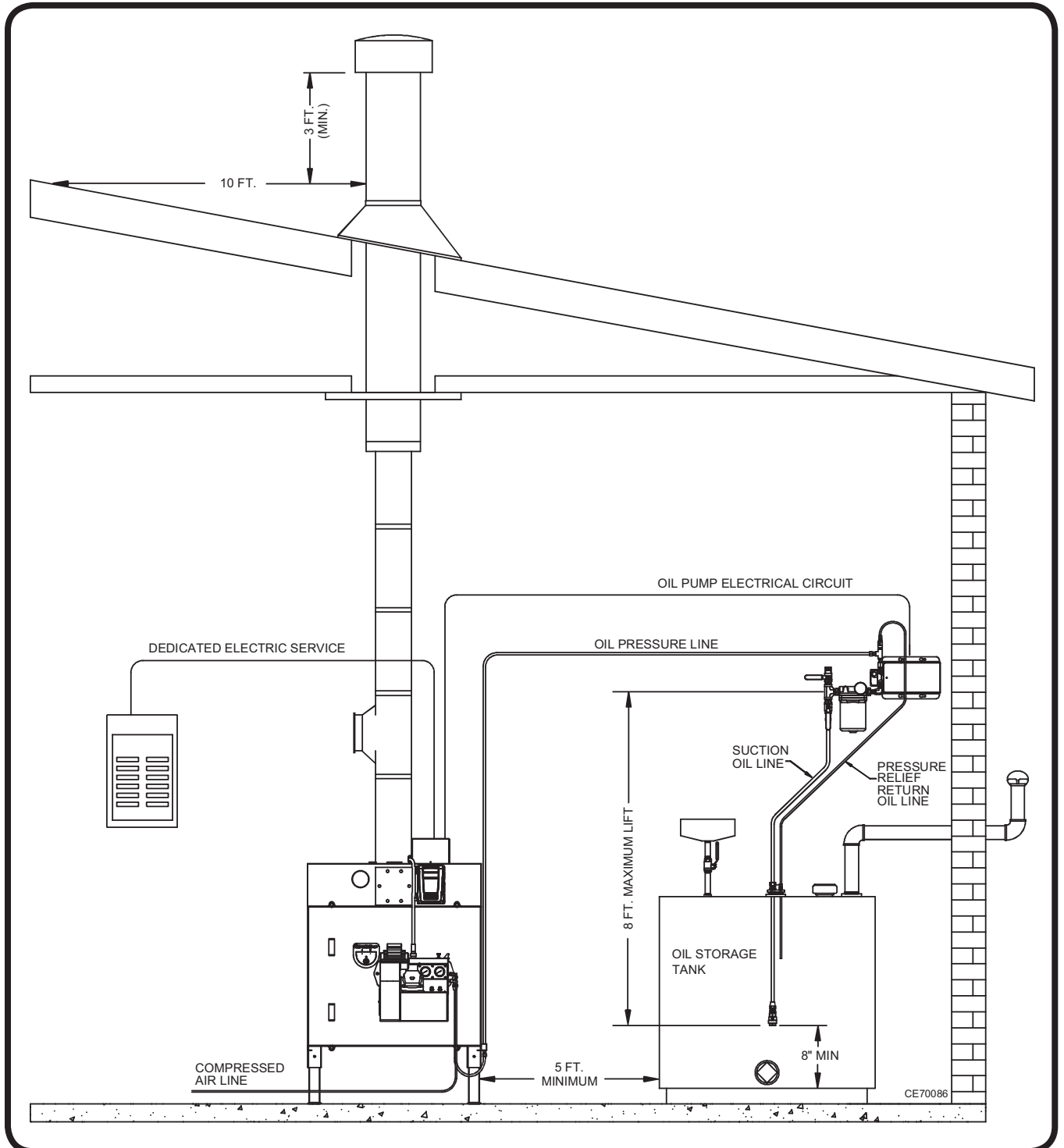

Figure 8: Typical Boiler Installation

BOILER INSTALLATION



WARNING: Carefully follow all installation instructions for safe and efficient operation.

Select a location:

There are several considerations when selecting a location for the boiler:

- (1) Do not obstruct shop personnel or equipment
- (2) Find a location where the boiler can easily be moved into place.
- (3) The installation must meet the clearance to combustible material requirements (Figure 9)
- (4) The location must be safely accessible for maintenance and service
- (5) The installation must comply with all local codes and regulations
- (6) Keep the stack / chimney system simple. A complicated stack with multiple elbows and long horizontal runs will reduce the natural draft of the unit which can damage critical burner components.

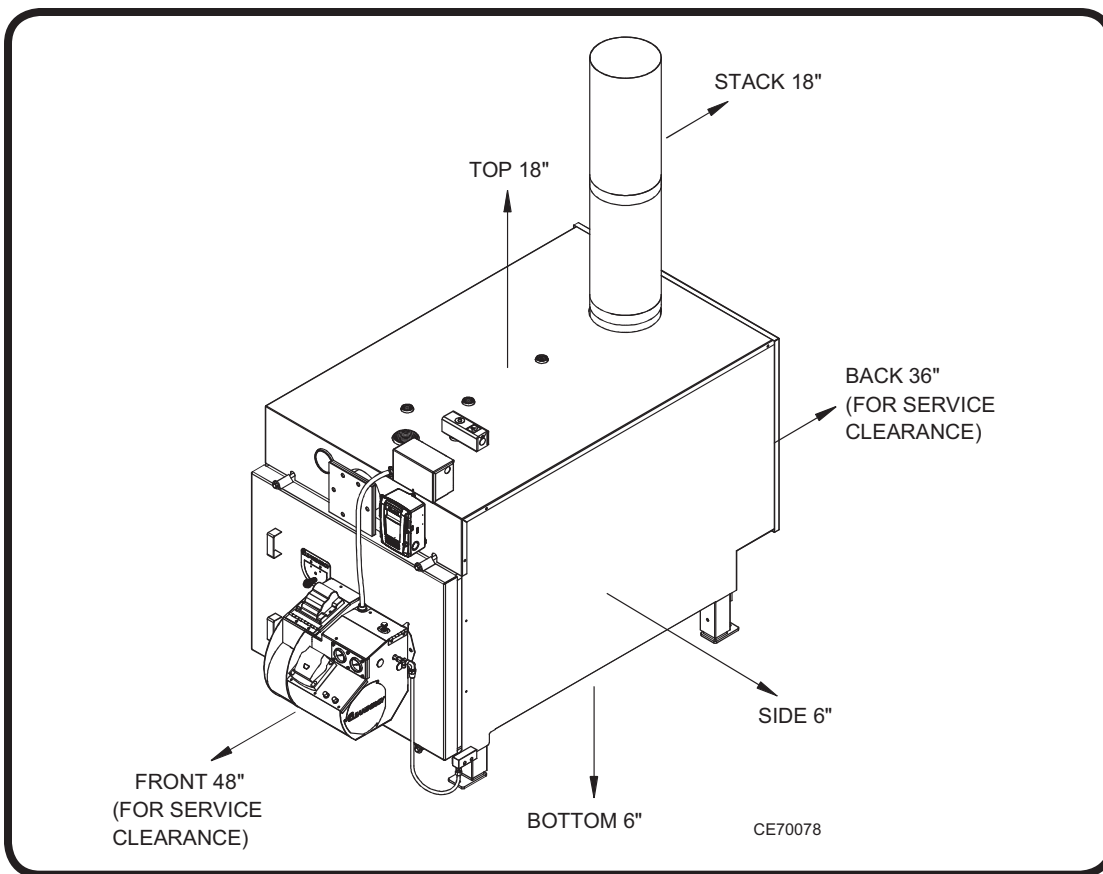

Figure 9: Clearances to Combustible Materials

Minimum Distances from Combustible Materials

CE-340 BOILER

Front (Burner)	18" (48" for service clearance)
Back	18" (36" for service clearance)
Side	6"
Top	18"
Chimney Connection	18"

BOILER INSTALLATION

Mounting the Boiler in position:



WARNING: The floor or pad for boiler installation must support the weight of the boiler when it is full of water. A level concrete floor or pad is recommended.

- (1) Refer to Figure 8 for a typical installation.
- (2) Set the boiler in position.
- (3) Raise the four legs up if desired.
- (4) Fasten the four legs to the floor through the holes in the pads on the bottom of each leg.
- (5) Use a level to ensure the boiler is level front-to-back and side-to-side.

Connecting the electrical supply to the Boiler:



WARNING: Shut off main power to the boiler before making any electrical connections. ONLY a qualified electrician should run wire and make connections to the boiler. All wires must be the proper gauge and run in approved electrical conduit. All wiring must meet the requirements of the National Electrical Code.

Electrical Requirements:

120 V / 60 Hz
Single Phase
20 Amp dedicated circuit

- (1) Install a dedicated electrical circuit to the junction box above the burner.
- (2) Connect the wires according to the label found on the inside of the junction box cover or in the *wire diagrams section* of this manual. Use stranded copper wire to ensure a secure connection.

BOILER INSTALLATION

Installing the chimney components:



WARNING: Double wall “Class A” insulated stack must be used through any building penetration and for any exterior stack. Unapproved stack material and/or installation can create a fire hazard. Contact Clean Energy Heating Systems, LLC to purchase approved stack material for your installation.



CAUTION: Using single wall stack on the exterior of your building will cause the stack gases to cool rapidly and adversely affect the natural draft of the boiler. This will create a back draft and may damage critical burner components.

- (1) Refer to Figure 10 for a typical through-the-roof chimney illustration and Figure 11 for a typical through-the-wall chimney illustration.
- (2) Observe the following requirements when installing the chimney:
 - The CE-340 boiler requires 8” I.D. stack components.
 - Have a minimum of 10 feet vertical chimney to ensure -.02” w.c. draft over fire.
 - Keep horizontal runs short. Slope any horizontal sections at least 1/4” per foot.
 - Keep the stack installation simple. Multiple turns and horizontal runs will reduce the natural draft of the boiler which may damage critical burner components.
- (3) Single wall stack may be used inside the building. Observe proper clearances from combustibles. Do not put single wall stack in areas that may create a burn hazard to personnel.
- (4) Install a barometric damper, as shown in Figures 10 and 11, so that proper draft can be maintained. Follow the instructions provided with the damper for proper installation.
- (5) Use double wall “Class A” insulated stack when making a penetration through the roof or side wall of your building. Install proper flashing around the exterior penetration of the stack to make a water tight seal. Clean Energy Heating Systems, LLC recommends “Dektite” flexible pipe flashing, or equivalent, for through the roof installations.
- (6) Install a “Class A” non-restrictive stack cap only.



CAUTION: IF YOUR BUILDING UTILIZES AN EXHAUST FAN, ensure that there is adequate make-up air available. Lack of make-up air will create a vacuum in your building which will result in a back draft at the boiler. A back draft will damage critical burner components.

BOILER INSTALLATION

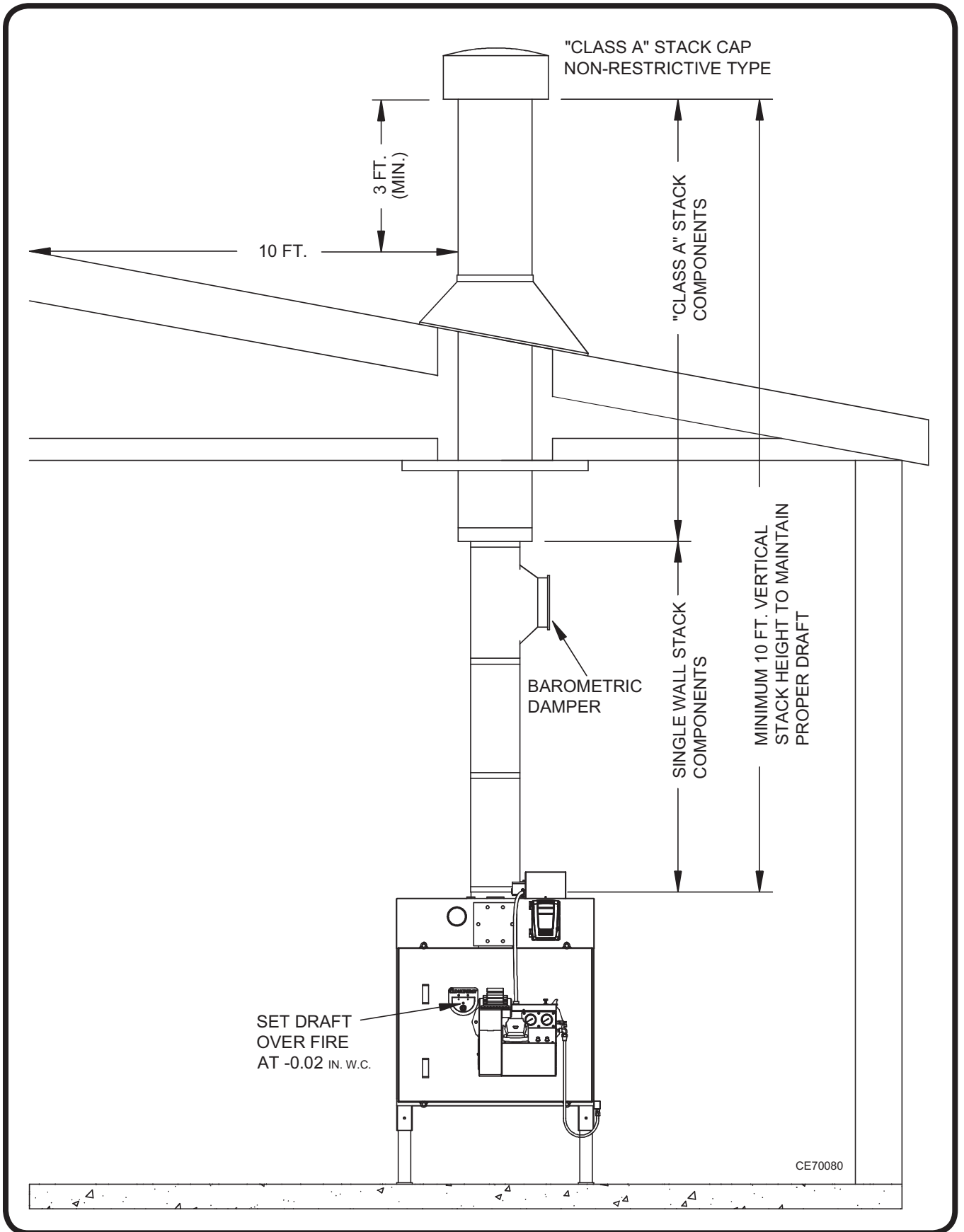

Figure 10: Typical Through-the-Roof Chimney Illustration

BOILER INSTALLATION

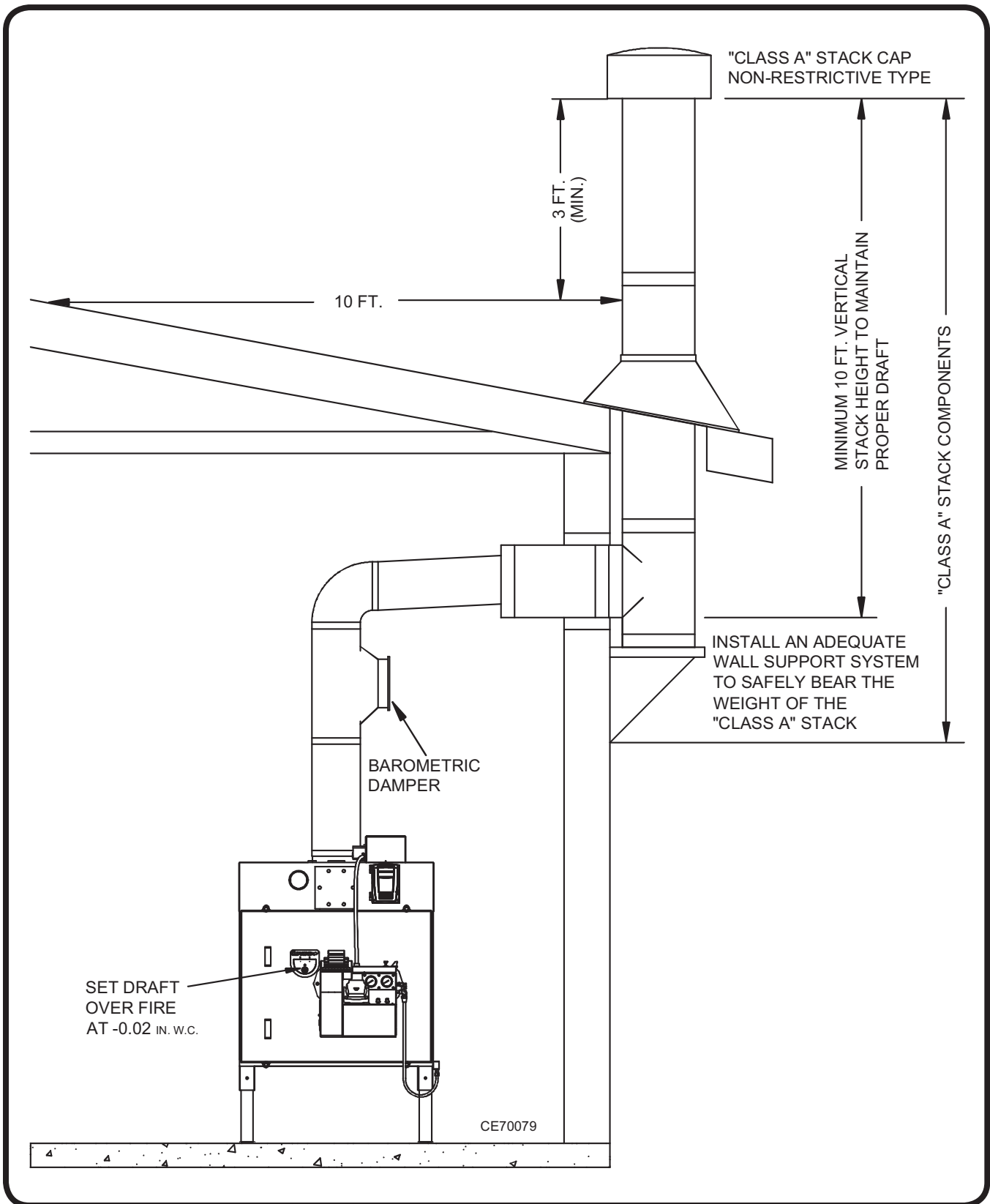

Figure 11: Typical Through-the-Wall Chimney Illustration

BOILER INSTALLATION

Oil storage tank setup:

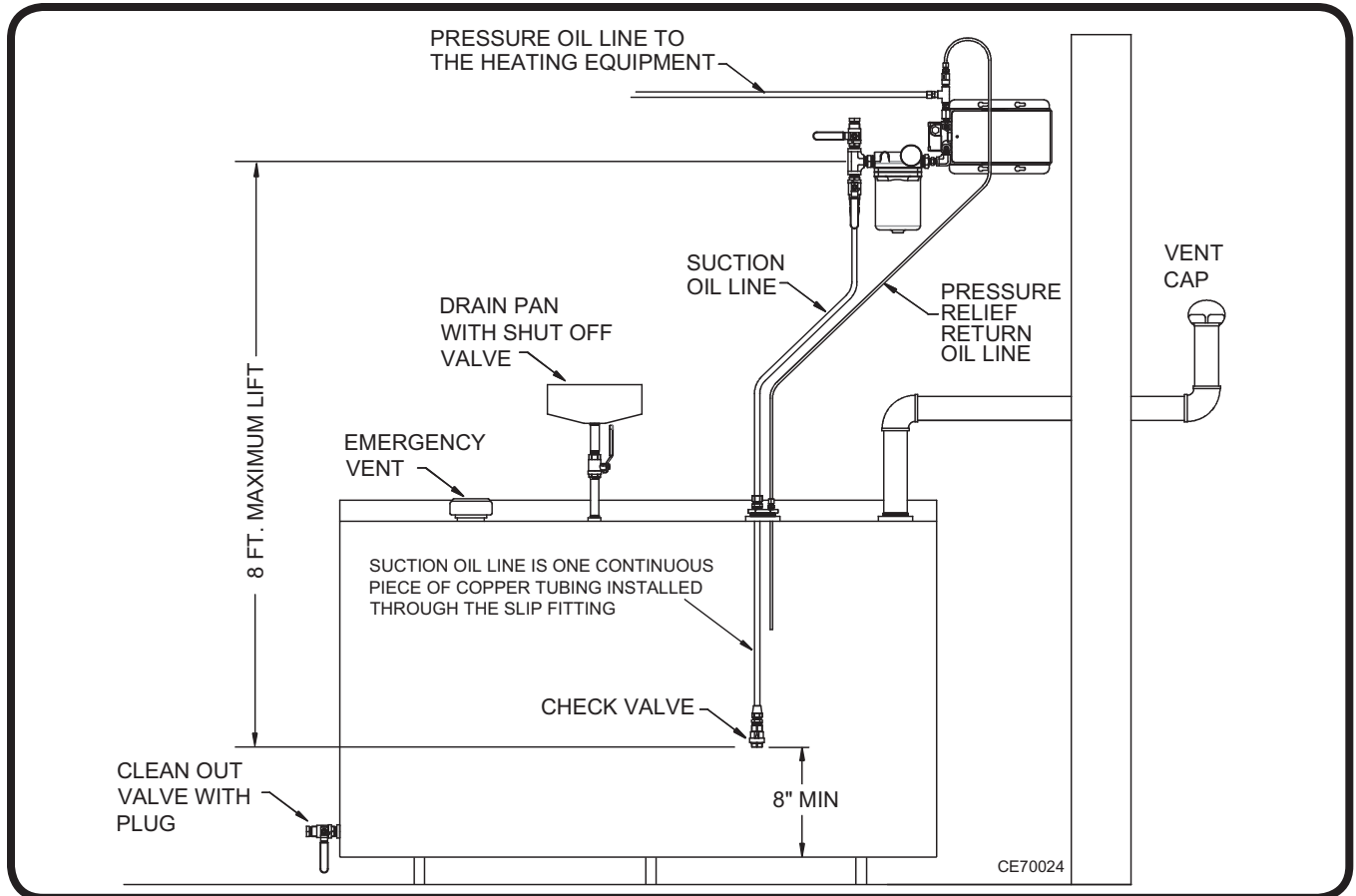

Figure 12: Typical Oil Storage Tank Installation

- (1) Refer to Figure 12 for a typical oil storage tank setup.
- (2) The tank must be installed according to all NFPA requirements and State and Local codes.
- (3) An inside tank is recommended.
- (4) Locate the tank in a position that will allow the oil pump to be mounted as close as possible
- (5) Only use a tank with a drain on the bottom. Over time, dirt and sludge will naturally accumulate on the bottom of the tank and there must be a way of removing this unwanted material.
- (6) Some state and local codes require the tank to be vented to the outside.
- (7) Educate all personnel what substances are allowed to be added to the used oil supply and apply the provided tank warning label near the fill location.

Installing the metering pump system and oil lines:



CAUTION: The metering pump must be mounted above the oil tank. The pump is not designed to take head pressure. If the pump is below the level of oil in the tank the pump seals may begin to leak.

Metering Pump Installation Guidelines:

- (1) Use non-hardening thread sealer for all threaded pipe fittings. DO NOT use teflon tape.
- (2) The pump must be installed with the shaft in the horizontal position and the oil outlet pointing up.

NOTICE: The gauge arrow on the front of the pump head must be pointing up.

BOILER INSTALLATION

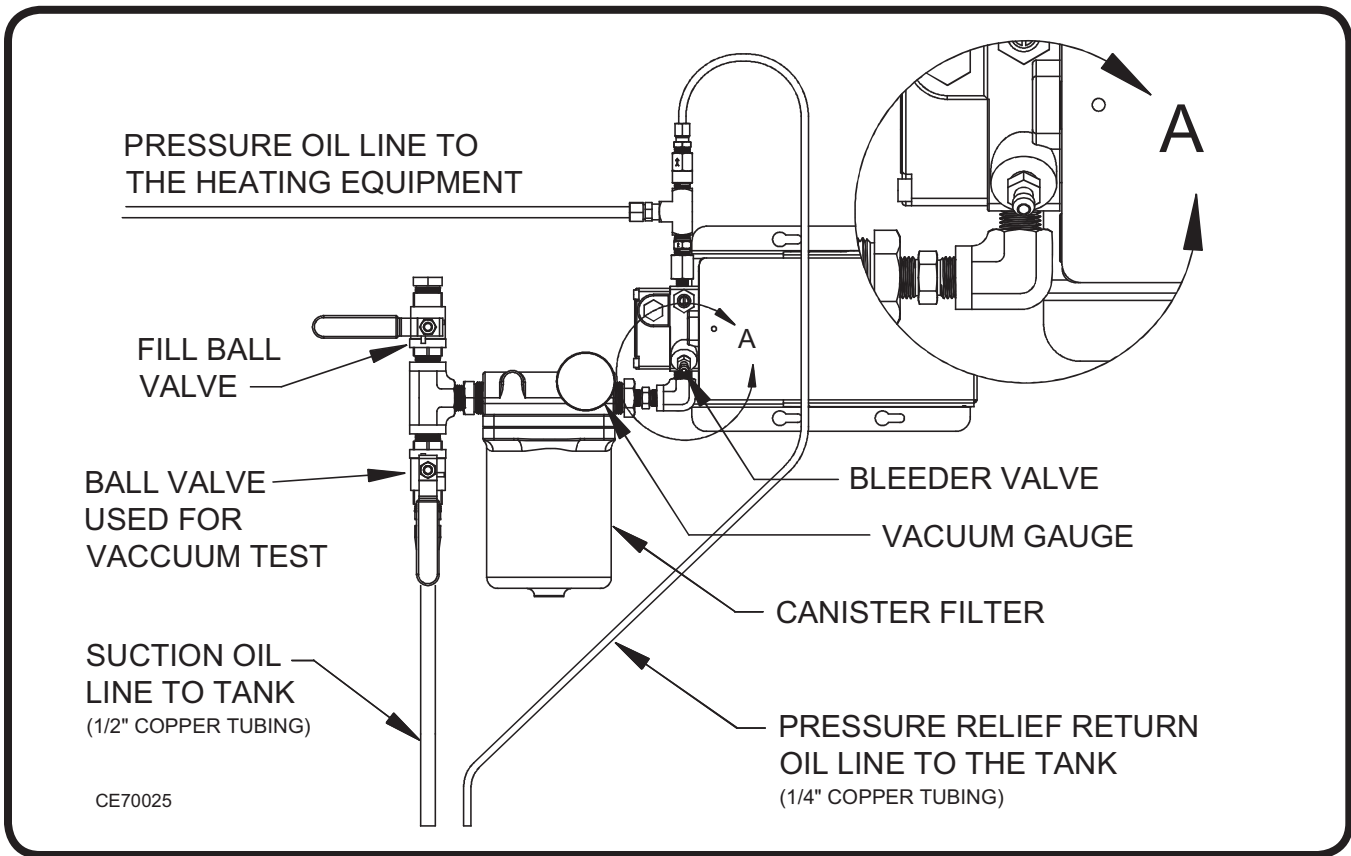

Figure 13: Typical Metering Pump Installation (Standard Mounting on a Wall)

- (3) The metering pump system is a fixed displacement pump. The pump shaft is driven by a garmotor at a specific rpm, for each specific model. This delivers a constant flow (gph) of fuel. Change in oil viscosity and temperature have very little effect on fuel flow. Therefore no oil pressure adjustment is needed for the metering pump system.
- (4) The metering pump must be mounted as close to the tank as possible. The suction oil line (length of oil line from the bottom of the tank up to the pump) must not exceed 8 vertical feet. Every 3 horizontal feet of suction line reduces the maximum allowable vertical lift by 1 foot.
- (5) The suction oil line must be a minimum of 8" from the bottom of the tank to reduce the likelihood of sludge and/or water being delivered to the boiler.
- (6) The metering pump system is not weatherproof. Mount the pump indoors only.

Mounting the metering pump assembly:

NOTICE: The metering pump system comes assembled for standard mounting on a wall.

STANDARD MOUNTING:

- (1) Refer to Figure 13 for a typical metering pump installation (standard mounting on a wall).
- (2) Use appropriate hardware to mount the metering pump system to the wall.
- (3) Keep the pump assembly as close to the tank as possible.

ALTERNATE MOUNTING:

- (1) Refer to Figure 14 for an illustration of the alternate horizontal mounting.
- (2) Loosen the pump head and rotate it 90°. The pump assembly may now be mounted in the horizontal position as on a shelf.

BOILER INSTALLATION

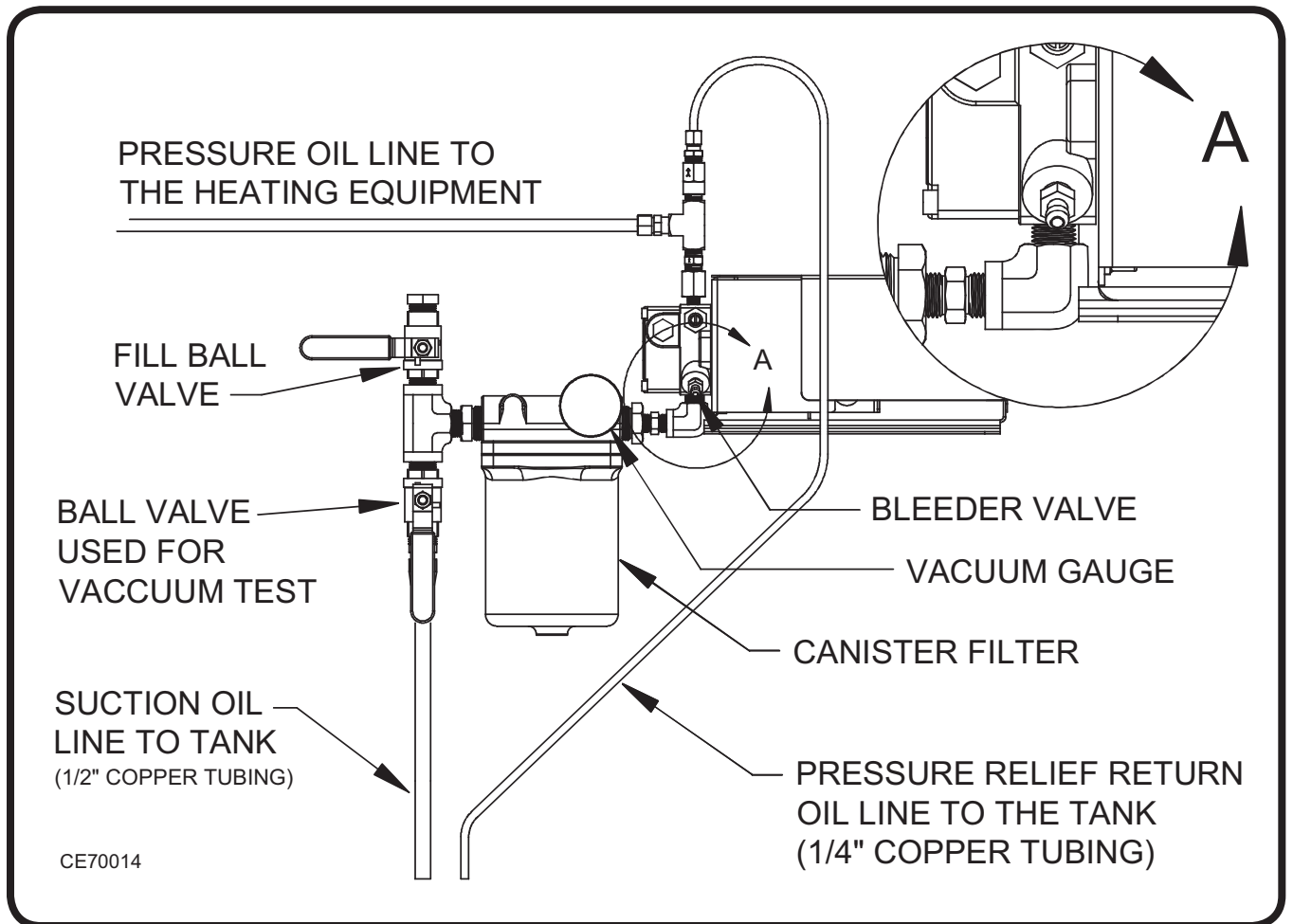

Figure 14: Alternate Horizontal Metering Pump Mounting

Installing the suction oil line:

- (1) Refer to Figure 15.
- (2) Measure the height of the tank. Reduce this measurement by 8" and mark the 1/2" copper suction line tubing at this length.
- (3) Install the 1/2" MNPT slip-through fitting into the side of the 2" duplex fitting marked "S".
- (4) Slide the 1/2" copper suction line tubing through the slip fitting in the 2" duplex fitting up until the mark that was made indicating 8" less than the height of the tank.
- (5) Install the 1/2" flare fitting into the foot valve (arrow on foot valve pointing toward the flare).
- (6) Flare the 1/2" copper suction line tubing and install it on the foot valve.
- (7) Insert the suction tubing into the tank and tighten the 2" duplex fitting.
- (8) Carefully bend the 1/2" copper suction line tubing up to the filter and cut it to length.
- (9) Flare the 1/2" copper suction line tubing and install it on the filter.

Installing the pressure relief oil line back to the tank:

- (1) Refer to Figure 15 and 16.
- (2) Install the 1/2" MNPTx1/4" compression fitting into the side of the 2" duplex fitting marked "R".
- (3) Run a piece of 1/4" copper tubing from the pump relief valve back to the tank.

BOILER INSTALLATION

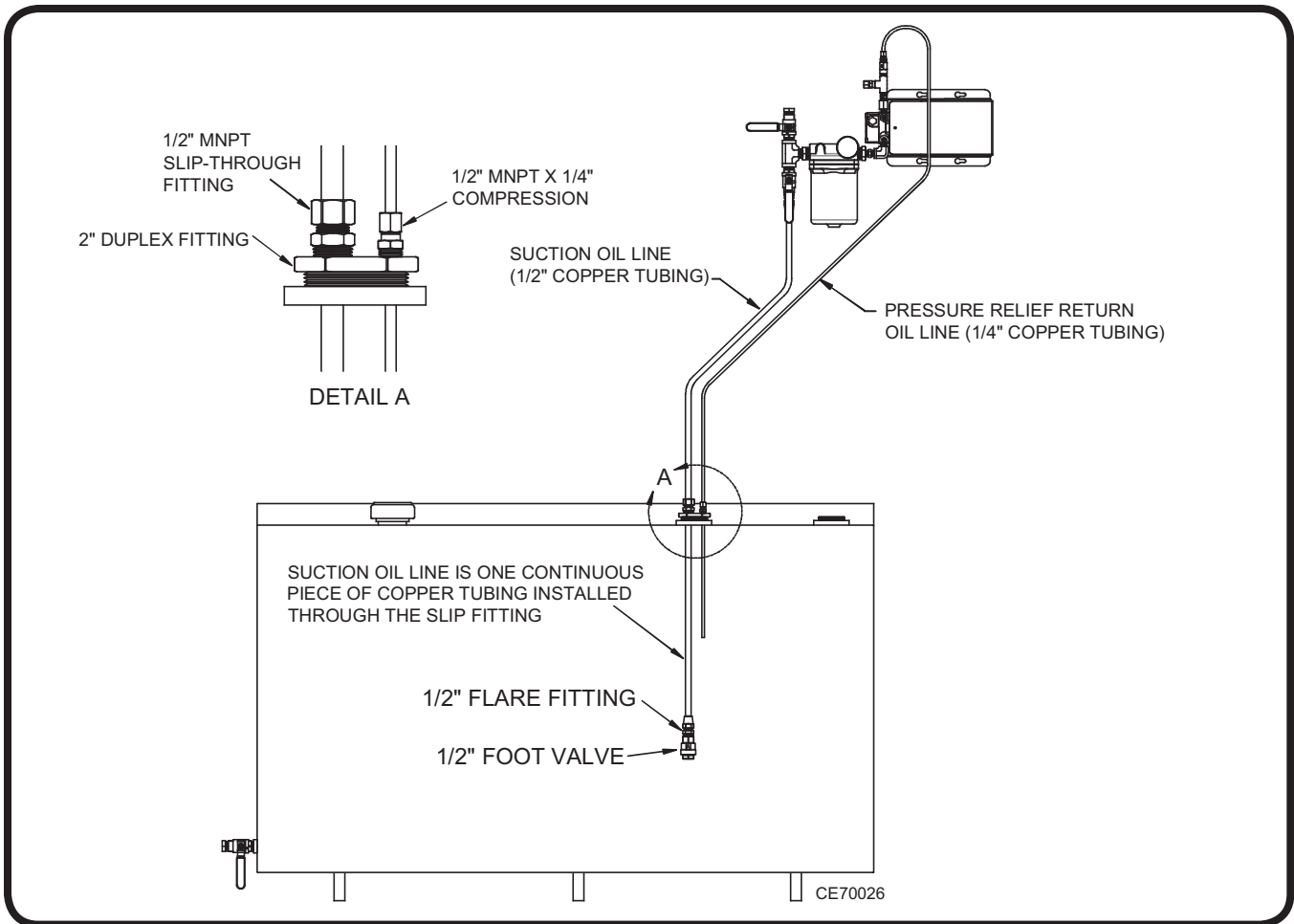

Figure 15: Installing the Suction Oil Line

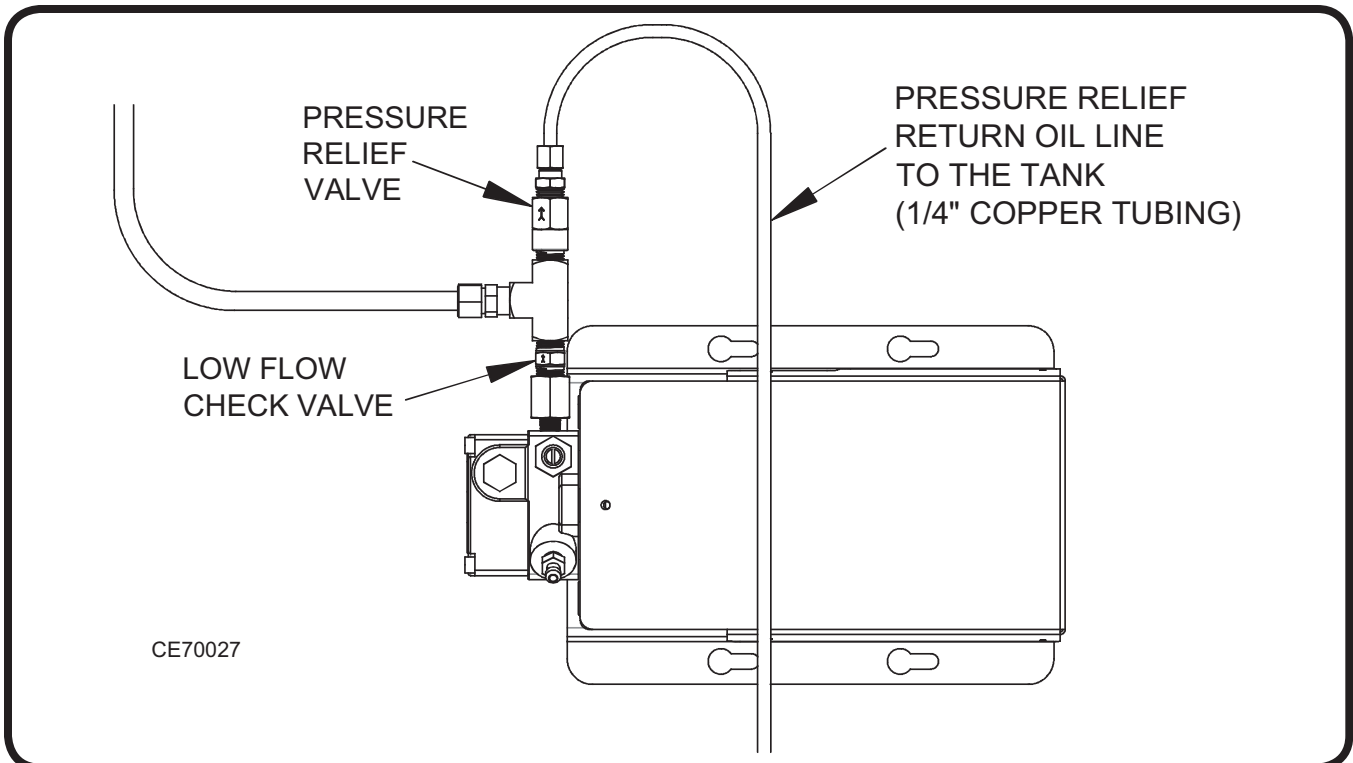

Figure 16: Metering Pump Pressure Relief Valve

BOILER INSTALLATION

Installing the pressure oil line to the boiler:

- (1) Refer to Figure 17 to view the pump oil outlet options.
- (2) Determine the desired position of the oil outlet and rotate the 1/4" T accordingly.
- (3) Determine the length of copper tubing needed for the pressure line (from pump to boiler) and use the appropriate sized tubing. If the pressure line is less than 100 feet, 3/8" copper tubing can be used. If the pressure line is greater than 100 feet, use 1/2" copper tubing.

NOTICE: There are installations that will operate well with a long pressure oil line. However, to ensure proper performance with variables such as oil temperature and viscosity, Clean Energy Heating Systems does not recommend exceeding 150 feet of total pressure oil line.

- (4) Refer to Figure 18.
- (5) Connect the pressure oil line to the aluminum connector block on the side of the boiler.

NOTICE: By connecting the oil line to the connector block, the swivel fitting is utilized which allows the front clean out door to be opened without disconnecting the oil line.

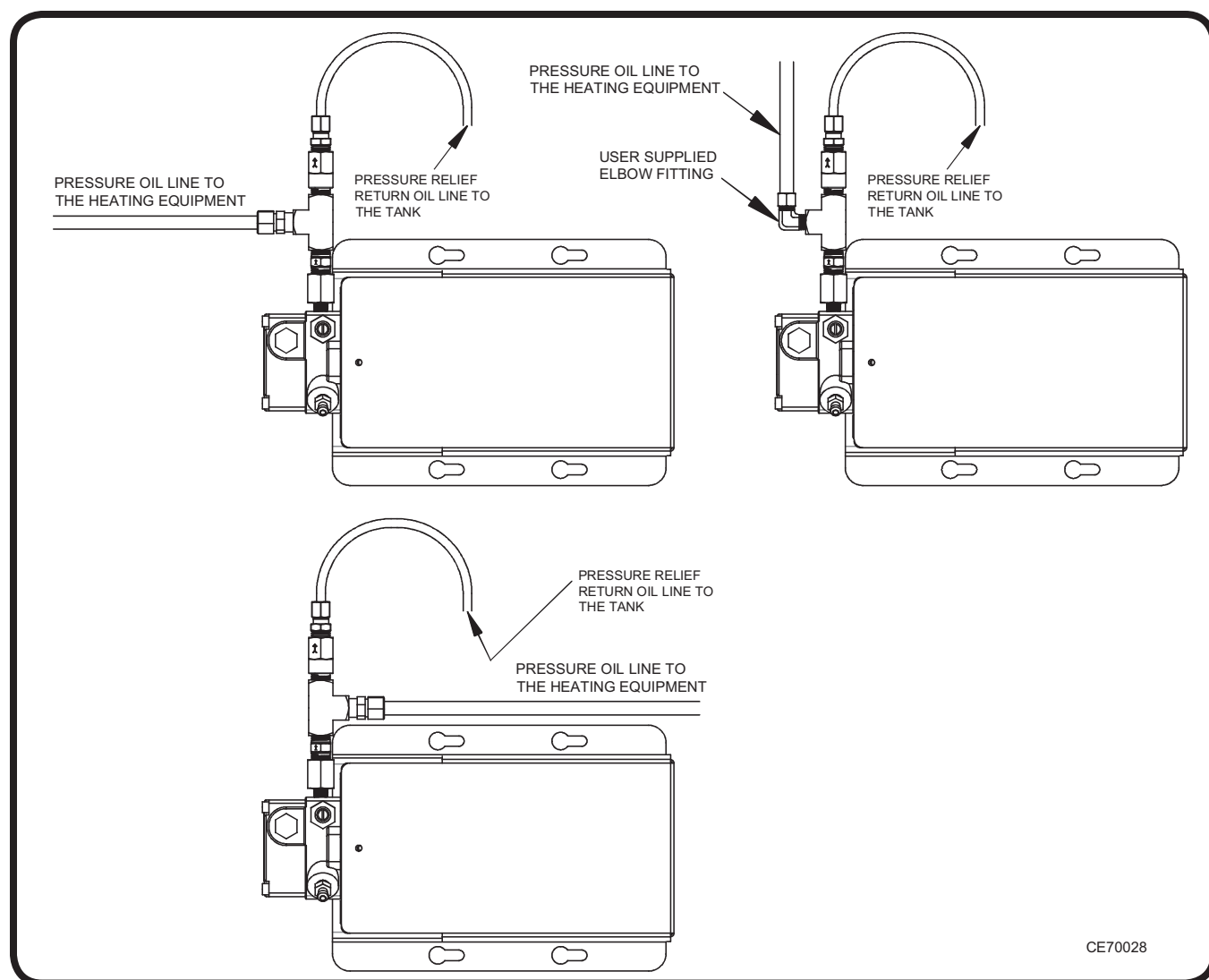

Figure 17: Metering Pump Oil Outlet Options

BOILER INSTALLATION

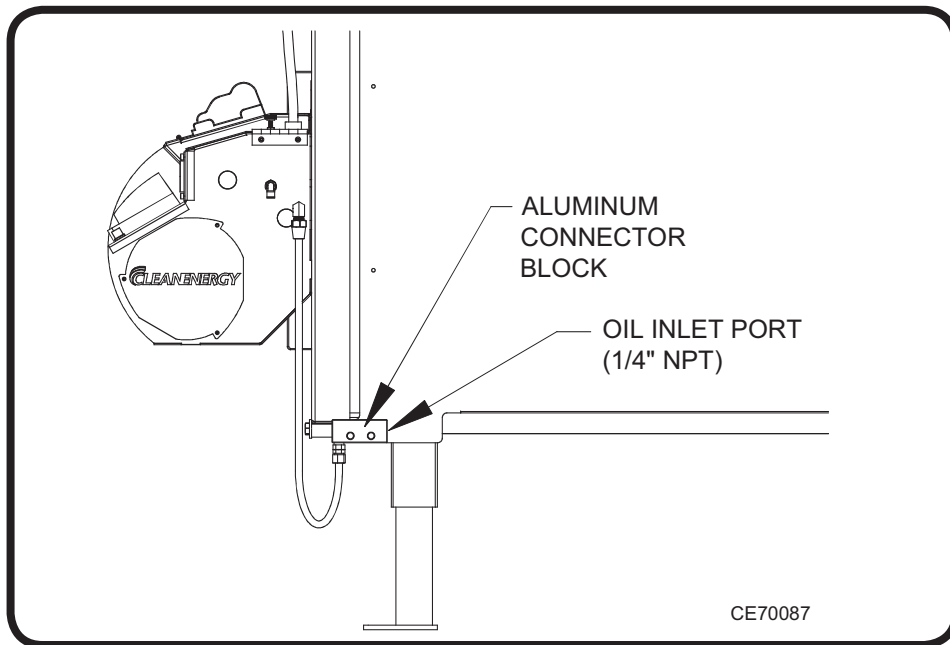

Figure 18: Connecting the Pressure Oil Line to the Connector Block

Connecting the Compressed Air Line:

- (1) Refer to Figure 19.
- (2) mount a water trap / air regulator (adjusted to 50 psi) and shut-off valve close to the boiler.
- (3) Run a flexible hose to the air inlet on the side of the burner. Carefully secure the air line to ensure it does not come in contact with any hot metal surfaces.

NOTICE: If a flexible hose is not used the air line will need to be disconnected from the burner to swing the front door open.

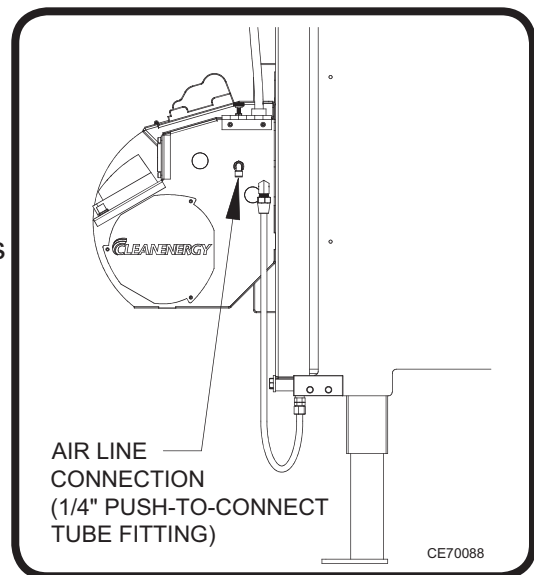

Figure 19: Installing the Air Line

Installing the wall thermostat:

- (1) Use the digital wall thermostat provided with the boiler.
- (2) Mount the wall thermostat according to the instructions provided with the thermostat.
- (2) Mount the thermostat on an interior wall and in a location that will be shielded from drastic temperature changes such as a door being opened.
- (3) Mount the thermostat at eye level to allow for easy viewing and adjustment.
- (4) Run the thermostat cable from the wall thermostat to the T-T terminals on the boiler control. Install a jumper wire between the T-T terminals on the primary control on the burner.

Changing the Wall Thermostat Batteries:

- (1) A low battery indicator will be displayed on the front screen to indicate low battery strength.
- (2) There is about a two week time frame to replace the batteries once the indicator comes on.
- (3) Follow instructions included with the thermostat to replace the batteries.

BOILER INSTALLATION

Design and Installation of the Hydronics System:

NOTE: Each install is unique. Contact your plumbing and hydronics expert to determine the layout and design of the system.

- (1) Water Temperature returning to the boiler must be above 140 °F. This will reduce condensation and thermal shock to the boiler.
- (2) The circulator should pump away from the expansion tank to reduce air problems.
- (3) Controls and valves must be used for multiple zones and for in floor heat to ensure the water temperature supplied to the floor is not too hot, and the water temperature returning to the boiler is not too cold.
- (4) The expansion tank must be sized according to the amount of water in the entire hydronics system. Take into account if antifreeze is added to the system.
- (5) Serious damage will occur if leaks occur in the hydronics system and excessive make-up water is being added. Make-up water will introduce oxygen which will lead to corrosion.
- (6) Incorporate an air separator and air vent to properly purge all air from the system to allow proper water circulation.
- (7) Refer to Figure 21 for typical single zone connections.
- (8) The Pressure Reducing Valve (Boiler Fill Valve) should be set at 12 psi.
- (9) Refer to Figure 20. A water pressure safety relief valve must be installed (supplied with boiler). Run a pipe from the relief valve discharge to within four inches of the floor for safe pressure relief.

Recommended Microprocessor Boiler Control Settings:

Hi Limit	180 °F
Hi Limit Differential	20 °F
Low Limit	140 °F
Low Limit Differential	10 °F
Low Water Cut-Off Manual Reset - ON	

If the Microprocessor Boiler Control is not used, the following controls must be utilized for safe boiler operation. Refer to Appendix A for illustrations and wire diagrams.

Temperature Operating Control
- Clean Energy part# 50193

Low Water Cut-Off
- Clean Energy part #50194

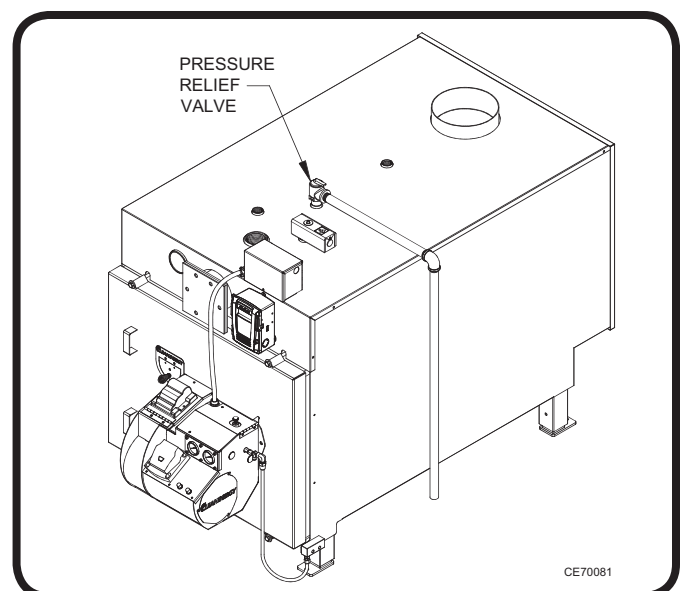
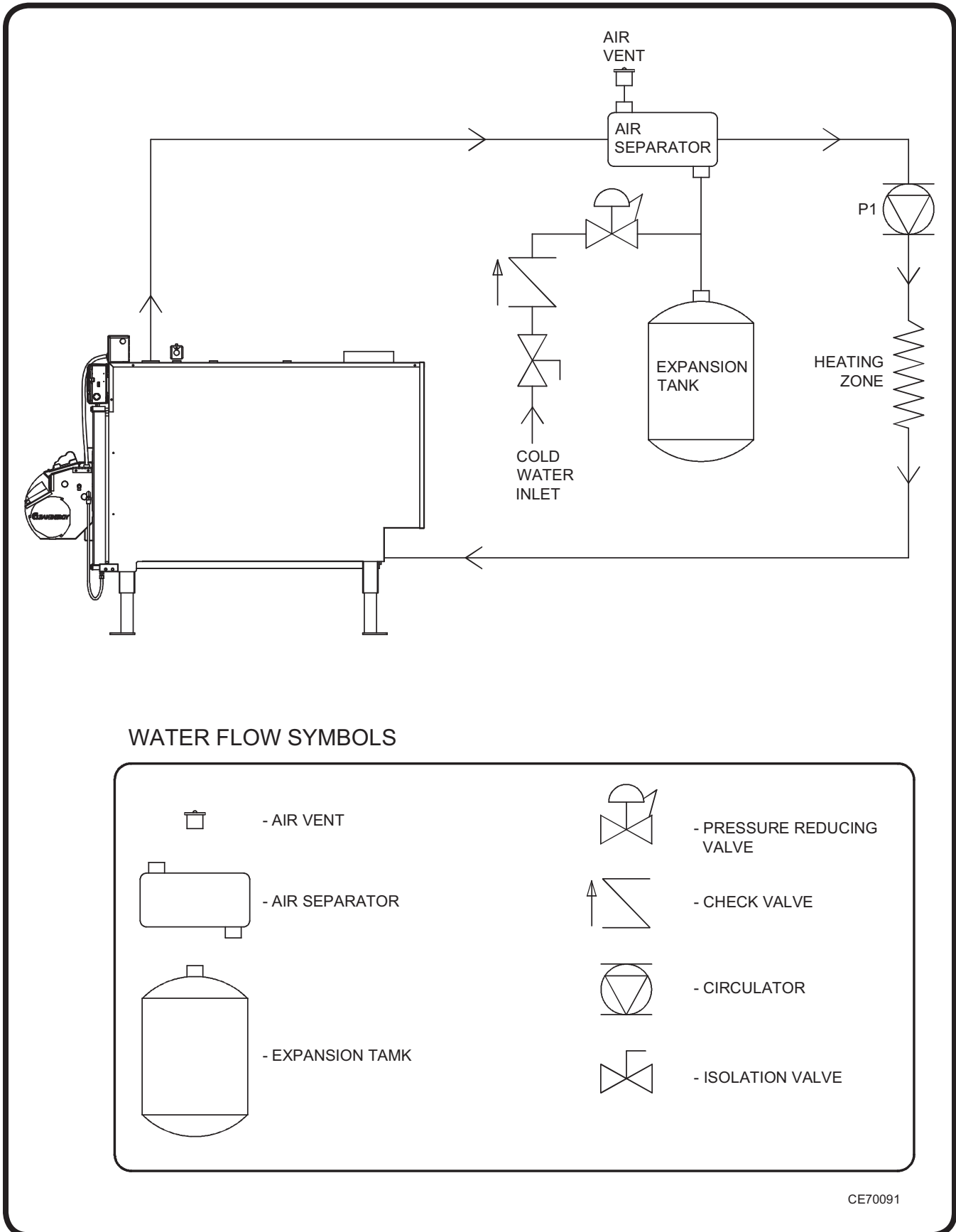
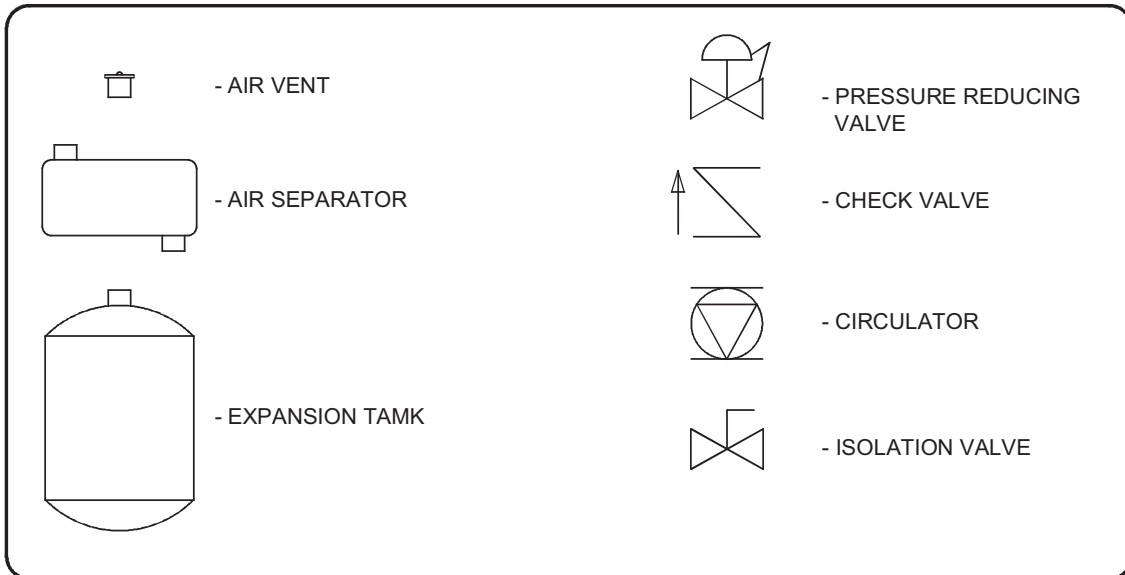

Figure 20: Installing the Pressure Relief

BOILER INSTALLATION



WATER FLOW SYMBOLS



CE70091

Figure 21: Typical Single Zone Connections

BOILER INSTALLATION

Inspecting the Boiler Installation:

NOTICE: The boiler installation should be inspected by qualified personnel before it is operated to ensure all state and local codes are followed.



CAUTION: Omitting or deviating from installation instructions in this manual may create hazardous operating conditions and void your warranty.

- (1) Confirm all clearances from combustibles as well as clearances for service are followed.
- (2) Make sure the microprocessor boiler control settings are correct for the application, and record all temperature settings and optional functions.
- (3) If the boiler is installed in a tight enclosed room, make sure there is enough make-up air for proper ventilation and combustion air (refer to figure 22).



WARNING: Failure to supply adequate combustion air to the boiler will create unsafe operating conditions.

- (4) After the system has run through a complete cycle, check all fittings for leaks.
- (5) Make sure the pressure relief valve and water feed system work properly.
- (6) Leave the Owner's Manual and boiler control manual near the boiler for future reference.



CAUTION: If the boiler is unattended during extremely cold weather and there is a component failure or power outage, frozen plumbing and water damage may occur in a short time. Equip the system so that it senses low temperature and initiates an effective action. Contact your local heating contractor for assistance.

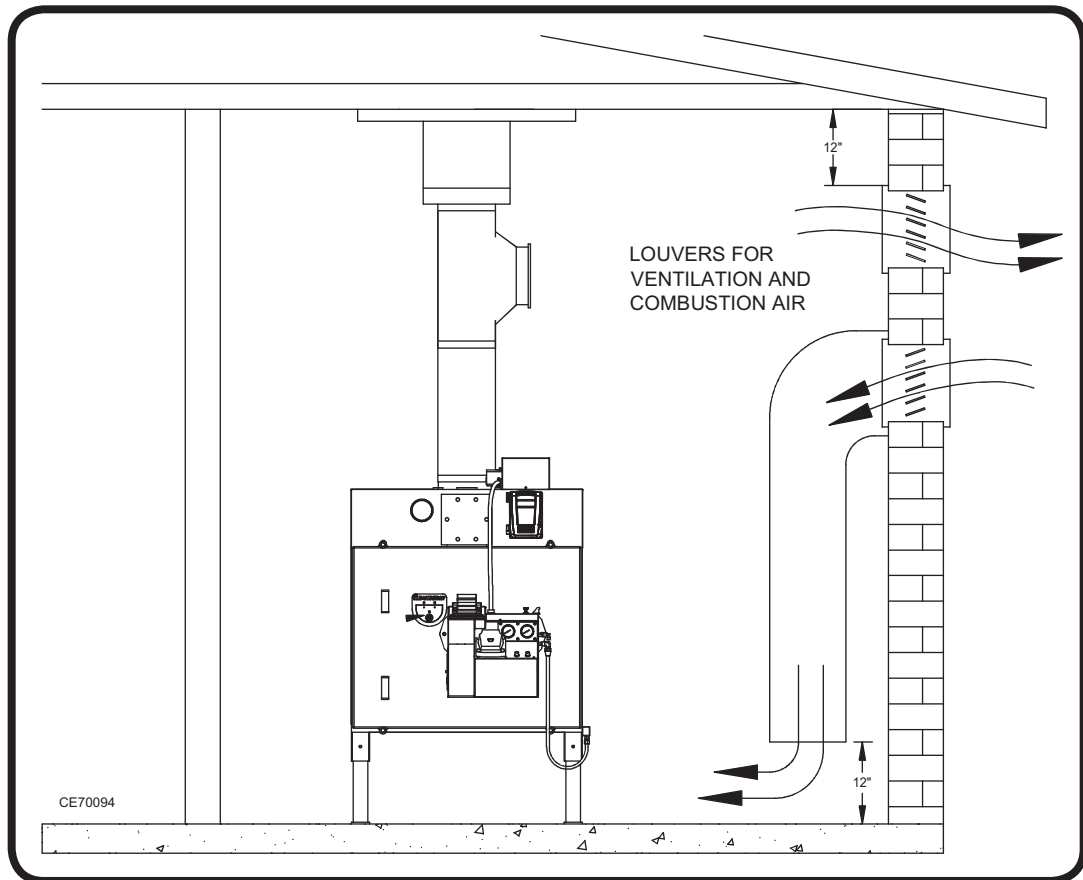

Figure 22: Louvers for Proper Ventilation and Combustion Air

BOILER CONTROLS AND SAFETY COMPONENTS

(1) Limit Control / Low Water Cut-Off

The Limit Control shuts the burner off if the water temperature in the boiler reaches the water temperature set point. The Limit Control will automatically reset when the water temperature drops to the required temperature.

The Low Water Cut-Off shuts the burner off if the the water level in the boiler goes below the Low Water Cut-Off sensor.

(2) High Limit Aquastat (Manual Reset)

The High Limit Aquastat shuts the burner off if the water temperature in the boiler reaches the High Limit water temperature set point. The High Limit Aquastat must be manually reset if it functions.

(3) Pressure Relief Valve

The Pressure Relief Valve will release excess pressure in the boiler (set at 30 psi).

NOTE: Install pipe from the pressure relief valve to within four inches of the floor to direct any release away from the boiler

(4) Temperature / Pressure Guage

This guage is used to monitor the water temperature and pressure within the boiler.

PREPARING THE METERING PUMP FOR START UP

- (1) Refer to Figure 23.
- (2) Remove the 1/2" NPT plug and open the ball valve on the inlet of the filter.
- (3) Pour oil into the inlet of the filter until the suction oil line, filter, and pump head are full.

NOTICE: A funnel can also be used to help direct the oil into the inlet of the filter.

- (4) Close the ball valve and insert the 1/2" NPT plug.
- (5) If the pressure oil line (from the pump to the boiler) is longer than 25 feet it is recommended to disconnect the oil line at the boiler and position a bucket under the line to catch the oil.

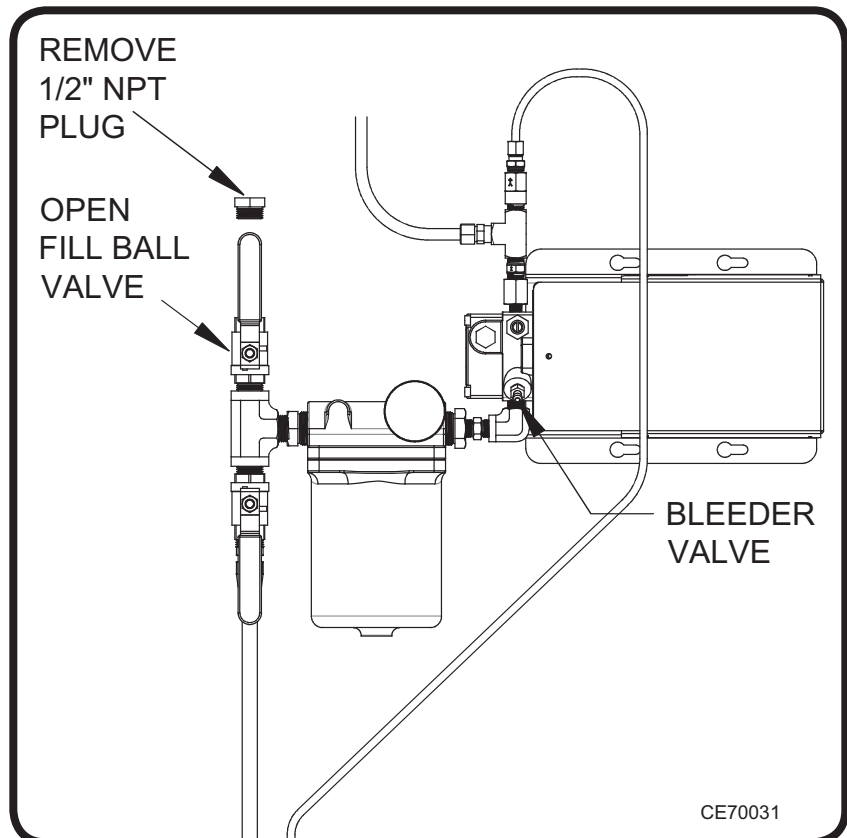

Figure 23: Priming the Metering Pump System

STARTING AND ADJUSTING THE BURNER

Preparing the burner for start up:

- (1) Plug the black cord into the top of the burner.
- (2) Turn on electrical power to the boiler.
- (3) Allow the burner heater element sufficient time to warm up the burner (time will vary according to ambient temperature). This usually takes 5 - 10 minutes. Once the burner has warmed up the “proving switch” will close and send power to the oil primary control.
- (4) Close the combustion air intake on the side of the burner. This will be opened up and adjusted once a flame is established.
- (5) Adjust the wall thermostat 10 - 20 °F above room temperature.
- (6) The burner should start when there is a call for heat. If the burner does not start, wait a few more minutes to ensure the burner is warmed up. If the burner still does not start try resetting the oil primary control (refer to the section on “Resetting the Oil Primary Control” in this manual).

Priming the oil pump:



CAUTION: Failure to prime the pump properly can result in unstable combustion, puff back, and heavy smoke.

- (1) After the burner starts, press and hold the reset button for 15 seconds until the yellow light on the primary control turns on (the burner will shut off).
- (2) Release the reset button. The yellow light will turn off and the burner will start again.
- (3) Within 15 seconds click (push and release) the reset button. This will transition the primary control to “Pump Prime” mode which will bypass the flame sensor and keep the pump on for 4 minutes.
- (4) Open the pump bleeder valve and purge all air bubbles from the pump (refer to figure 23).
- (5) After 4 minutes the yellow light on the primary control will turn off and the control will automatically return to standby mode.
- (6) Repeat steps 1 - 5 until the pump is fully primed and oil is delivered to the burner.

Adjusting the burner:

- (1) Once a flame is established adjust the combustion air intake and the compressed air pressure to maintain a healthy flame (refer to Figure 24).
- (2) The air intake plate on the left side of the burner can be adjusted to increase or decrease the pie shaped opening sizes to let in more or less combustion air.
- (3) The compressed air pressure can be adjusted by turning the knob on the air regulator.
- (4) Visually inspect the flame to ensure proper settings.
- (5) The flame should go 1/2 to 3/4 of the way down the combustion chamber, and should not impinge on any surface of the combustion chamber.

STARTING AND ADJUSTING THE BURNER

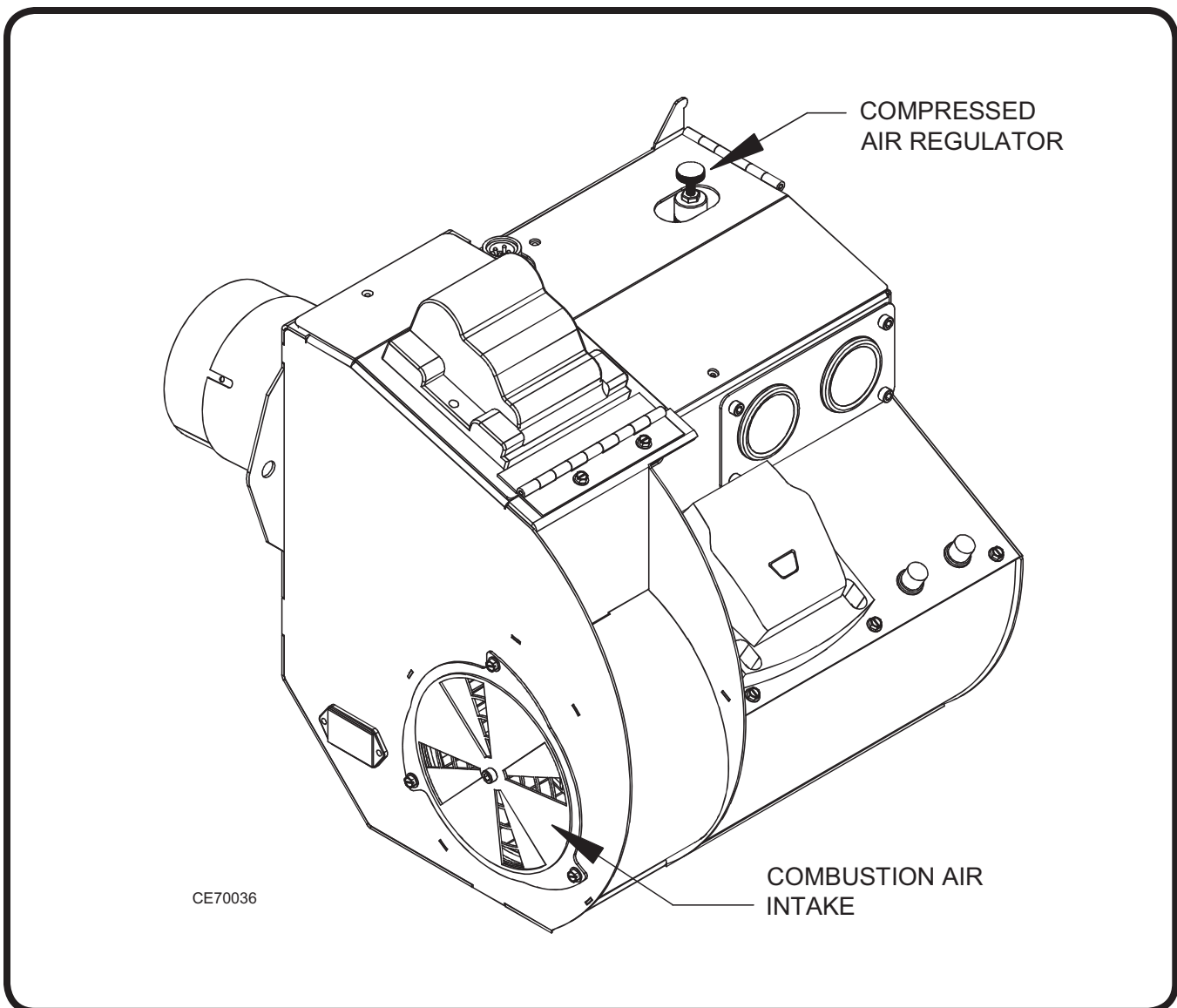

Figure 24: Flame Adjustment

RESETTING THE OIL PRIMARY CONTROL



WARNING: Explosion and Fire Hazard. Failure to follow these instructions could result in heavy smoke emission, puff back, fire and smoke hazards.

- (1) Refer to Figure 25 to locate the oil primary control reset button.
- (2) Do not attempt to reset the burner if there is excess oil in the combustion chamber, vapor has accumulated in the unit, or when the boiler is hot.

Oil flooded combustion chamber: Turn off power to the boiler and disconnect the burner cord. Open the clean out door and wipe out the accumulated oil before continuing.

Vapor filled combustion chamber: Allow the unit to cool for 30 minutes and all vapors to dissipate before resetting the oil primary control.

- (3) When the combustion chamber has cooled, and there is no vapor or excess oil in the combustion chamber, push the reset button for 3 seconds and release.
- (4) If the burner does not restart contact the Clean Energy Heating Systems service department.

RESETTING THE OIL PRIMARY CONTROL

Resetting the burner from restricted lock out:

NOTICE: If the control locks out three times before a call for heat is satisfied, it will enter restricted lockout mode in order to limit the amount of unburned oil in the combustion chamber.

- (1) Push the reset button in for 15 seconds. Release the reset button when the red light turns off and the yellow light turns on.

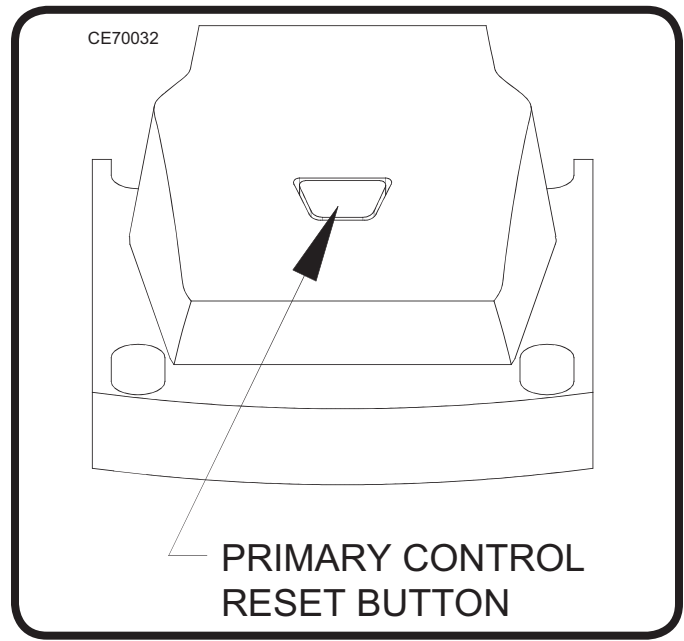

Figure 25: Oil Primary Control Reset Button

SETTING THE DRAFT



WARNING: Do not operate your boiler if a proper draft is not obtained or damage to critical burner components will occur.

- (1) Allow the boiler to run for 5 to 10 minutes.
- (2) Refer to Figure 26 to locate the draft gauge hole.
- (3) Insert a draft gauge through the hole in the observation port. Follow the manufacturer's instructions for adjusting the barometric damper to obtain $-0.02''$ w.c. draft over fire.
- (4) If a proper draft is not obtained, follow the instructions below to check for a vacuum in your building.

Checking for vacuum in your building:

- (1) Have someone slowly open an overhead door while you are taking a draft reading.
- (2) Watch the draft gauge and tell them to stop when you get a $-0.02''$ w.c. draft over fire.
- (3) Measure the opening created by the overhead door. This is the opening size you need for make up air to allow the boiler to draft properly.



Figure 26: Draft Gauge Hole in the Observation Port

MAINTENANCE

Periodic Maintenance Schedule:

- (1) Clean the oil filter and pump head screen.....once a year
- (2) Clean sludge and water from the tank.....once a year
- (3) Clean ash from the heat exchanger.....800 hours
- (4) Flush the nozzle adapter heater block.....2000 to 3000 hours

Cleaning the oil canister filter screen:

- (1) Place a container under the canister filter to catch any released oil.
- (2) Use a 3/16" allen wrench to loosen the canister.
- (3) Drop the canister down and remove the filter screen.
- (4) Thoroughly clean the filter screen in a parts washer.
- (5) Fill the canister 3/4 full with used oil (this will aid in pump priming) and slowly insert the filter screen back into the canister.
- (6) Tighten the 4 socket head screws in a crisscross pattern.

NOTICE: Do not over-tighten or the aluminum filter casting may crack.

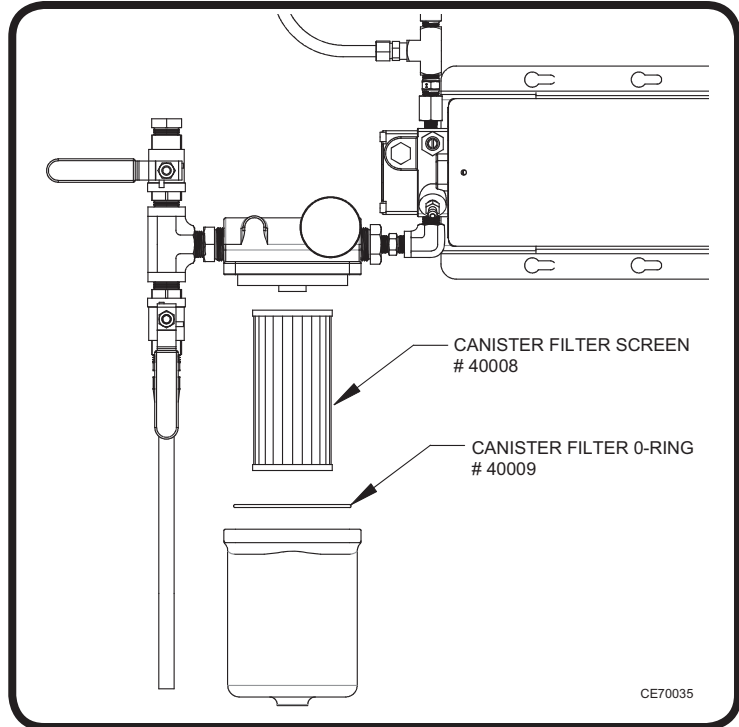

Figure 27: Removing the Oil Canister Filter Screen

Cleaning the oil pump head screen:

- (1) Place a container under the oil pump head to catch any released oil.
- (2) Use a 5/32" allen wrench to loosen the pump head cover.
- (3) Remove the cover, pump head screen and gasket. Carefully scrape the gasket off if any pieces remain stuck to the pump head.
- (4) Thoroughly clean the pump head screen in a parts washer.
- (5) Install a new pump head gasket and put the cleaned screen in place.
- (6) Tighten the 4 socket head screws in a crisscross pattern.

NOTICE: Do not over tighten or the aluminum pump head cover may crack.

- (7) Once the filter and pump head screen are clean, follow instructions in the "Priming the Metering Pump" section.

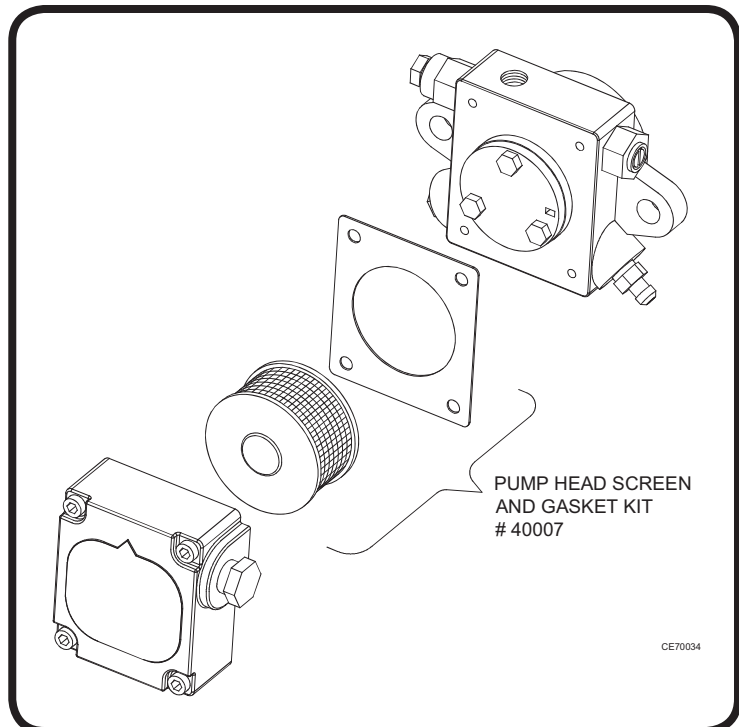

Figure 28: Removing the Oil Pump Head Screen

MAINTENANCE

Cleaning sludge and water from the bottom of the tank:

NOTICE: Because of the nature of used oil handling practices, it is very difficult to keep all water and sludge out of the used oil supply. Drain the used oil supply tank at least once a year to ensure no unwanted substance is being delivered to the boiler.

- (1) Connect a tube to the drain on the bottom of the tank and collect a sampling in a drain pan or bucket. Keep draining the tank until all water and sludge has been removed.
- (2) If there is no drain on your supply tank insert a transfer pump with the suction line inserted down to the bottom of the tank. Keep pumping out the tank until all sludge and water has been removed.

Cleaning ash from the heat exchanger:



CAUTION: Wear safety goggles, gloves, long sleeves and a dust mask when cleaning ash from the boiler. The accumulated ash is in the form of a fine powder and may cause irritation.



CAUTION: DO NOT attempt to clean ash from a hot boiler. It is a burn hazard as well as a fire hazard when the hot ashes are disposed of.

- (1) Refer to Figure 29.
- (2) Turn OFF power to the boiler and disconnect the power cord from the top of the burner.
- (3) Remove the four (4) bolts from the front clean out door.
- (4) Carefully swing open the front clean out door.
- (5) Remove the combustion sleeve and support blocks.
- (6) Remove the back shrouding. Remove the six (6) nuts fastening the back clean out door.
- (7) Brush out the combustion chamber and use an industrial vacuum to clean out the remaining ash.
- (8) Use a 3" flue brush to completely remove ash from the flue tubes.
- (9) Remove the chimney if necessary. Make sure there is no obstruction in the chimney.
- (10) Fasten all clean out doors and chimney components.

NOTE: It is recommended to use Anti-sieze on the clean out door bolts to allow easy removal for future cleanings.

Flush the nozzle adapter heater block:

- (1) Refer to Figure 30.
- (2) Open the igniter hinge cover on the burner.
- (3) Remove the electrode
- (4) Loosen the oil line swivel fitting with a 9/16" open end wrench.
- (5) Disconnect the air line by pushing on the release ring and pulling the tube out of the fitting.
- (6) Disconnect the quick disconnect electrical connector.
- (5) Carefully remove the entire aluminum nozzle adapter heater block from the burner.
- (6) Remove all the components from the nozzle adapter heater block.
- (7) Remove all the plugs from the oil ports with a 5/32" allen wrench.
- (7) Clean the nozzle adapter heater block in a parts washer. A tube cleaning wire brush (rifle barrel cleaning brush) can be used to properly clean the oil ports.
- (8) Blow out all passages with a compressed air blowgun.
- (9) Put all the plugs and components back on the nozzle adapter heater block and re-install it in the burner.

MAINTENANCE

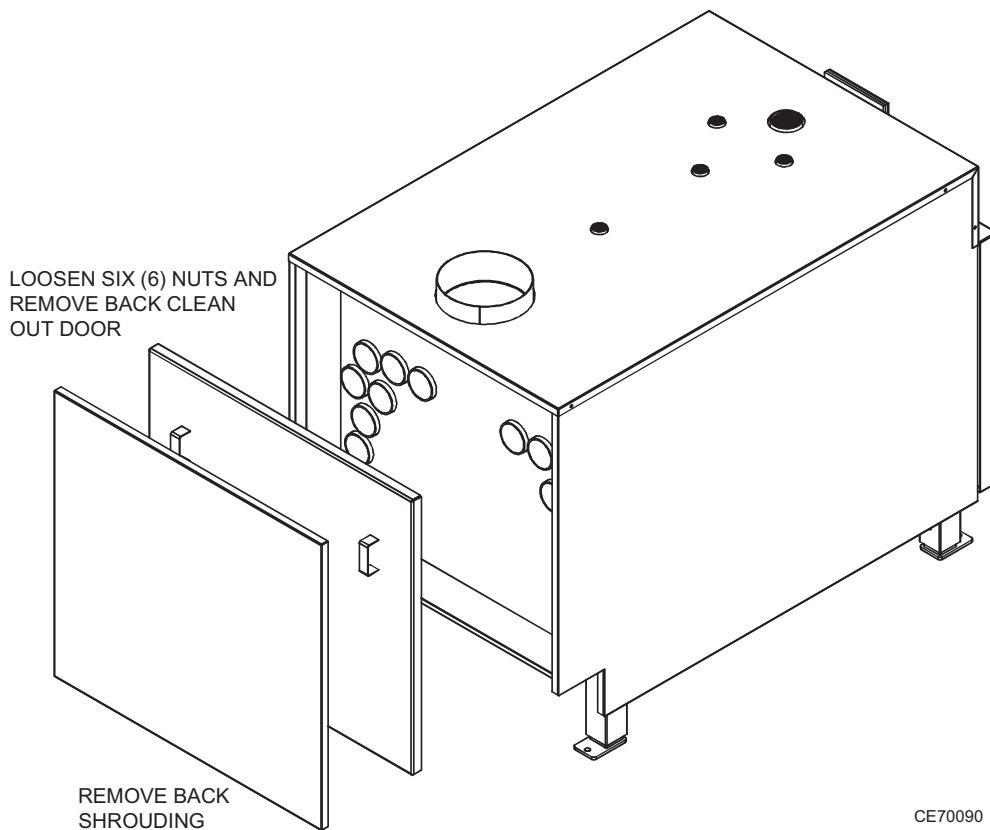
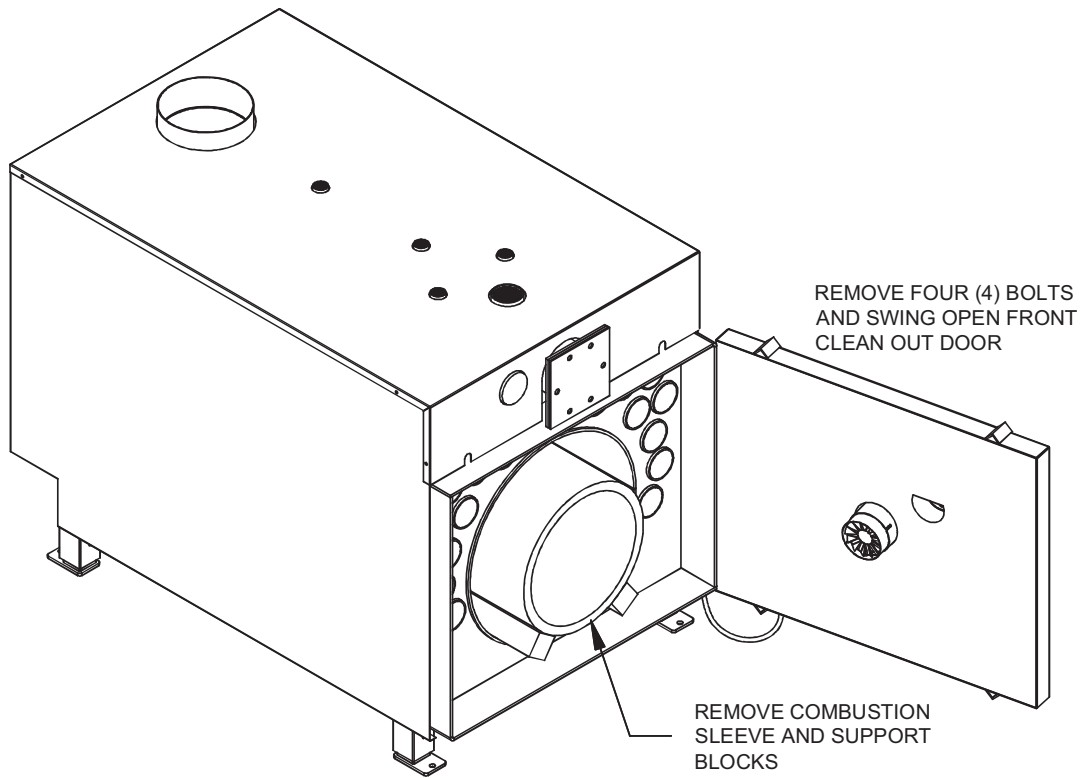
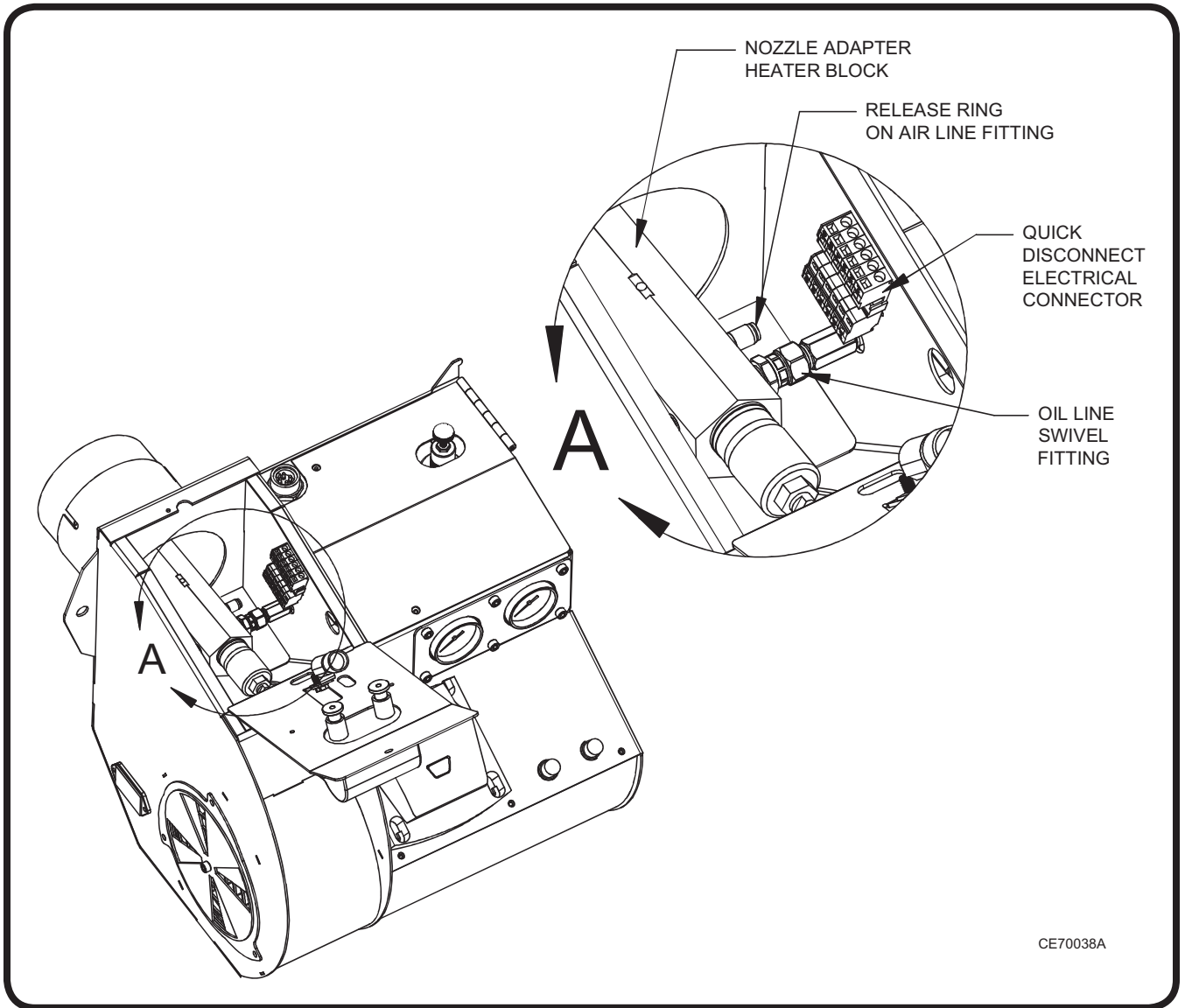

Figure 29: Cleaning Ash From the Heat Exchanger

MAINTENANCE



Nozzle adapter heater block with all components and plugs removed.

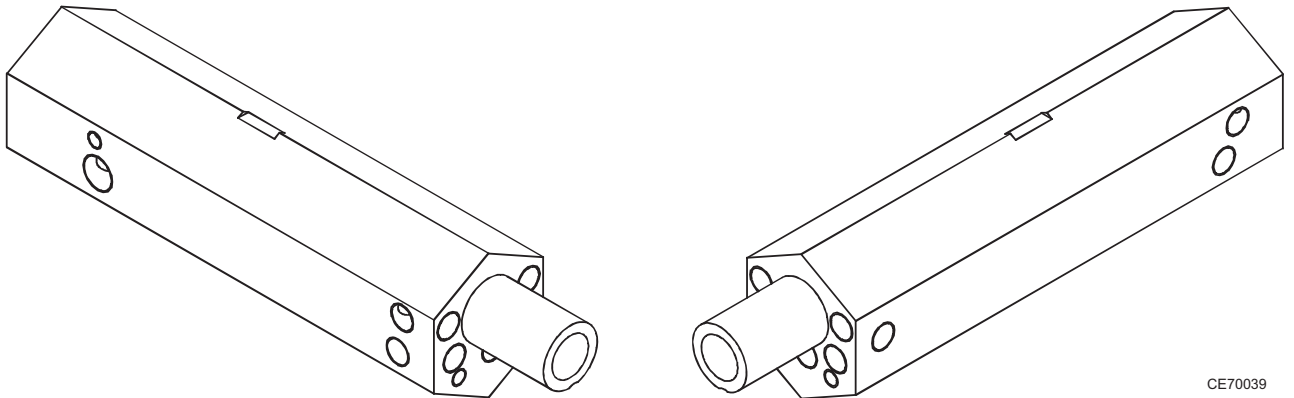
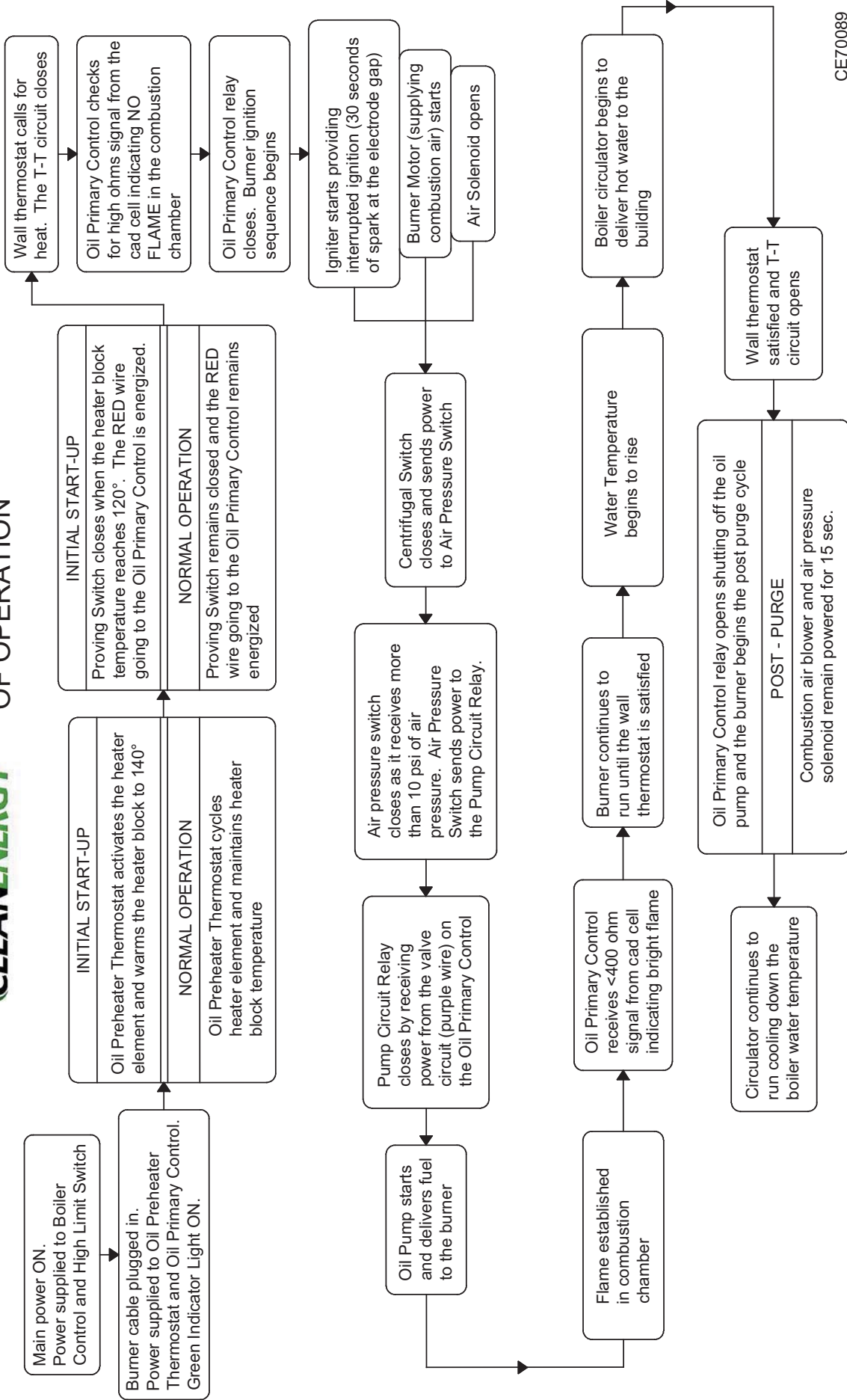

Figure 30: Flushing the Nozzle Adapter Heater Block



BOILER SEQUENCE OF OPERATION



CE70089

BOILER DIMENSIONS

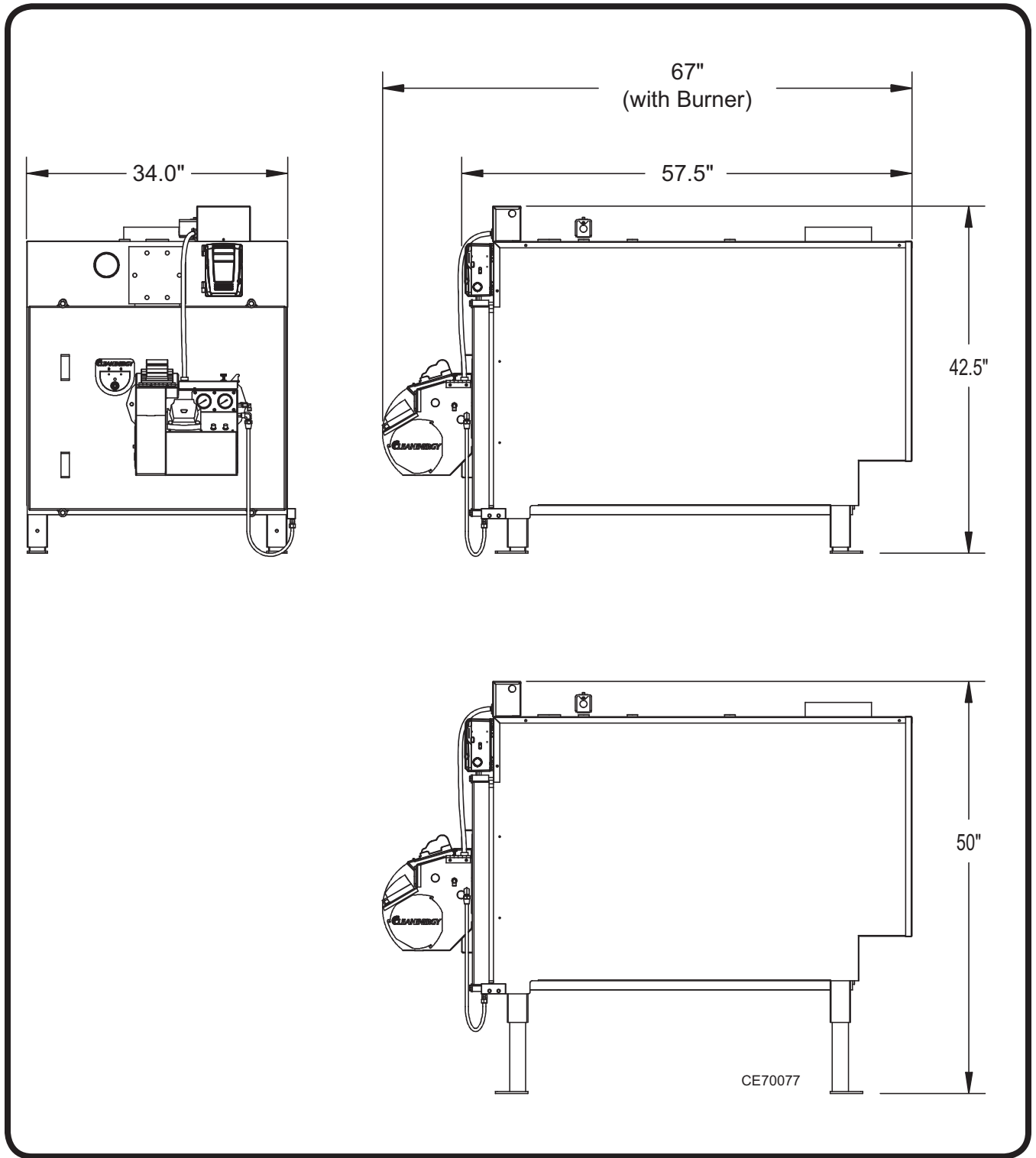

WIRE DIAGRAMS

CE-340 BOILER CABINET WIRE DIAGRAM:

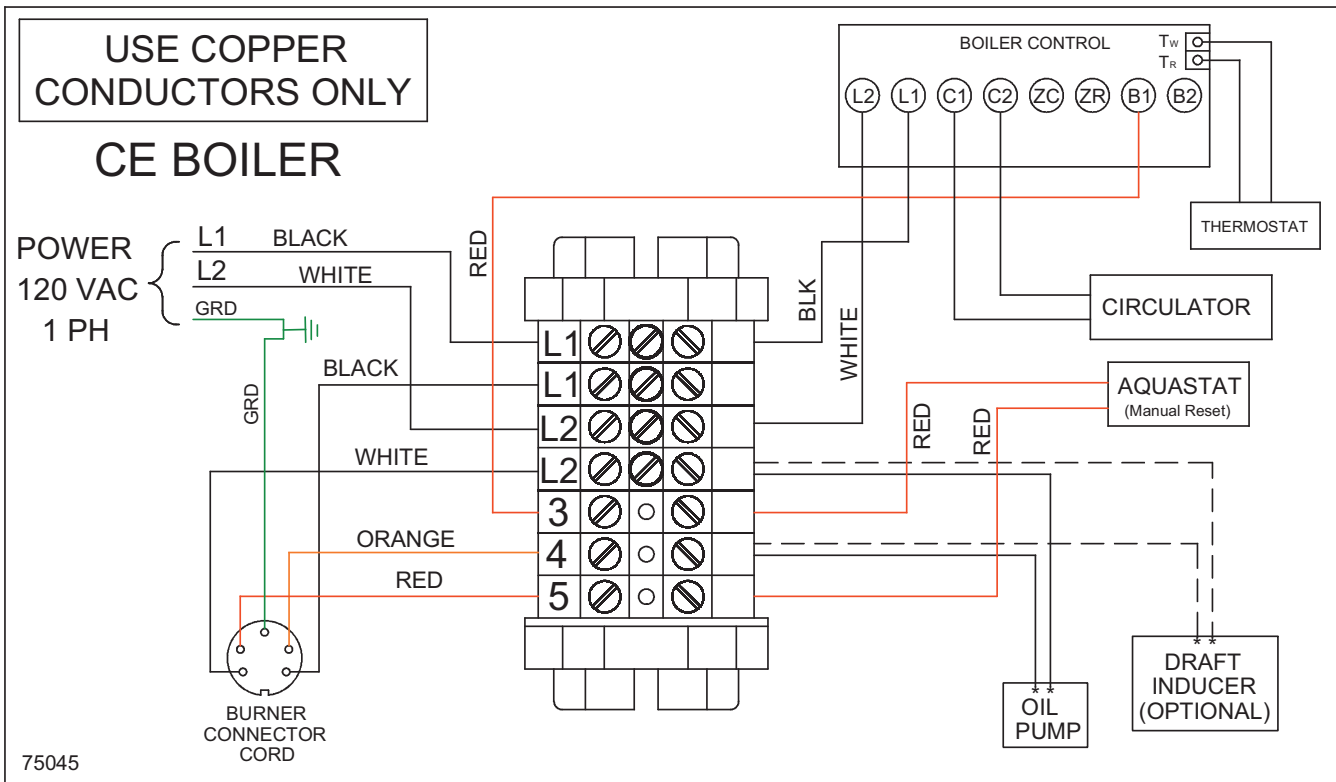

WIRE DIAGRAMS

CE-4 BURNER WIRE DIAGRAM:

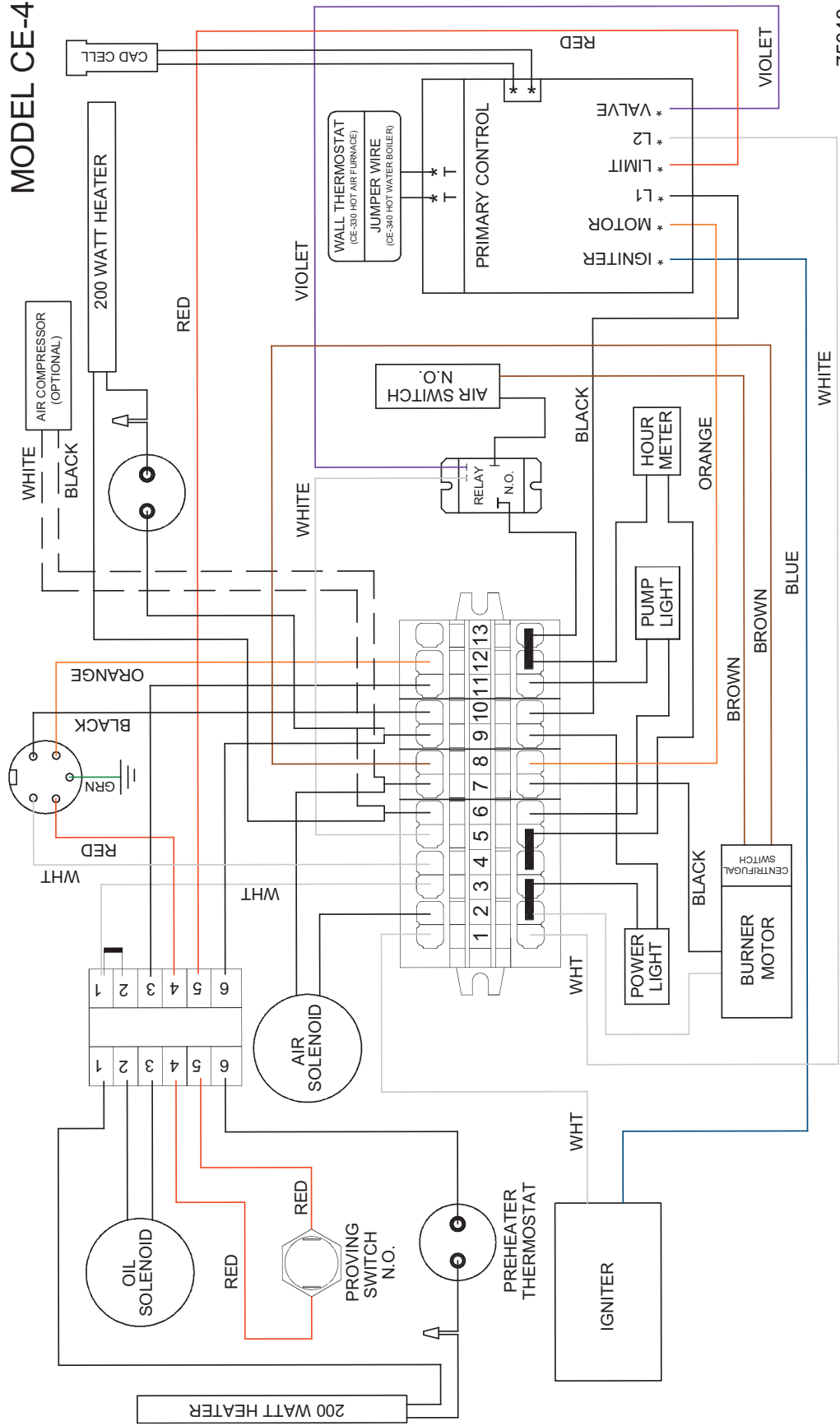

75043

CE-3 / CE-4 BURNER ASSEMBLY

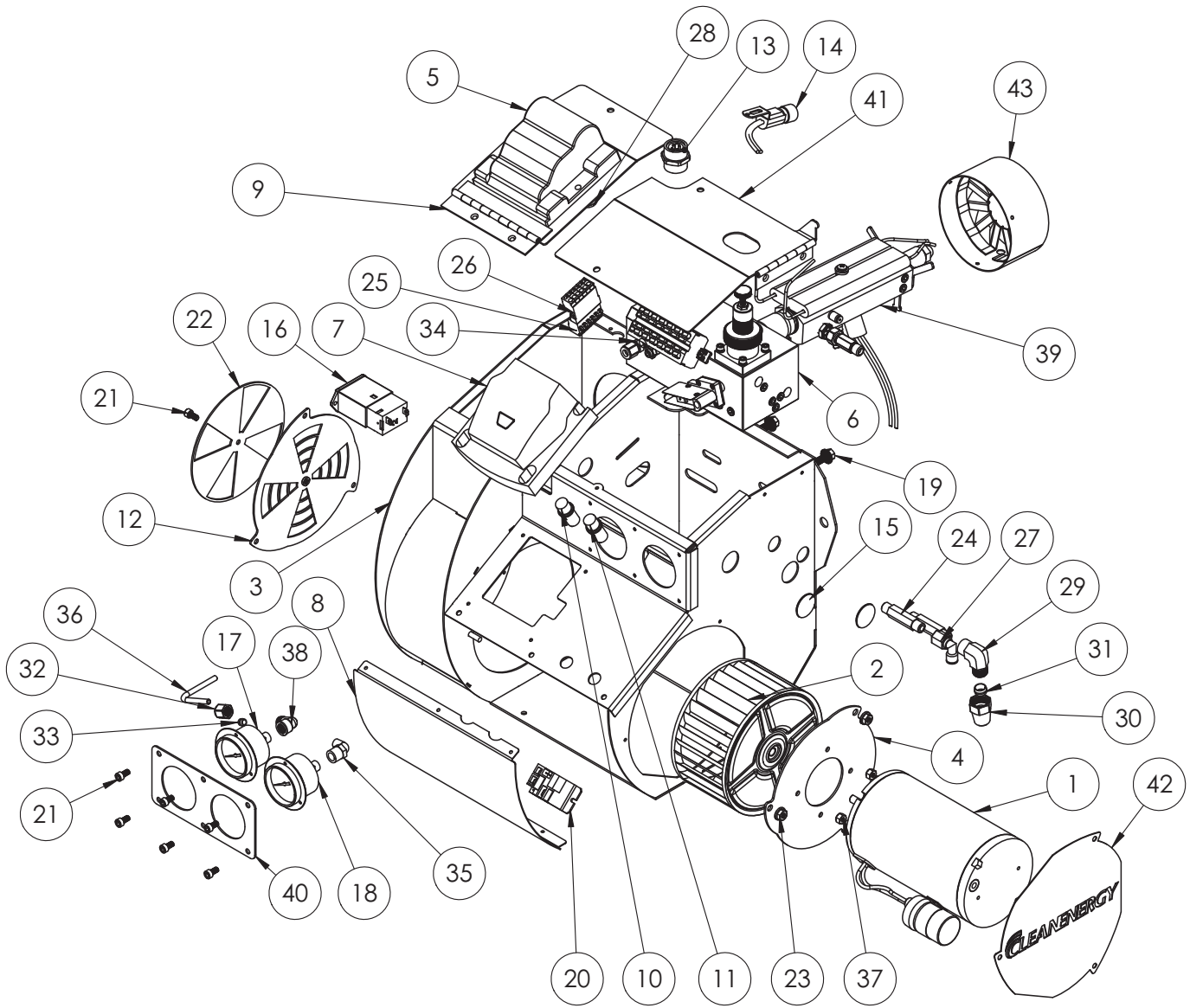

ITEM	PART #	DESCRIPTION	QTY.
	60300	CE-3 Burner Assembly	
	60400	CE-4 Burner Assembly	
1	30017	Burner Blower Motor	1
2	50015	Squirrel Cage - Burner	1
3	65001	Burner Housing	1
4	20034	Motor Mount Plate	1
5	50020	Igniter	1
6	50008	Burner Manifold Block	1
7	50019	Primary Control	1
8	20033	Front Motor Cover	1
9	65002	Ignitor Hinge Plate	1
10	30034	Amber Light	1
11	30033	Green Light	1
12	65006	Air Intake - Inner Plate	1
13	30025	Burner Receptacle (5-Wire)	1
14	30022	CAD CELL	1
15	30057	Plug - push in 7/8" hole	2
16	30016	Hour Meter	1
17	50016	Oil Pressure Gauge	1
18	50017	Air Pressure Gauge	1
19	58014	HHCS 1/4 -20 x 1/2	2
20	30009	Relay SPST	1
21	58033	Cap Screw Socket Head 10-24 x 3/8 SS	7
22	20037	Air Intake - Outer Plate	1
23	58023	Flange Serrated Nut 10-24 Z	3
24	50065	1/8 MP X 2 HEX NIPPLE	2
25	30038	Terminal Block Quick Disconnect - Female	1
26	30026	Terminal Block Quick Disconnect - Male	1
27	50056	1/4 TUBE-1/8 FNPT 90	1
28	30027	Post Contact - Igniter	2
29	50059	3/8 CP x 1/8 FP 90o	1
30	50051	3/8" Compression Nut	1
31	50052	3/8" Compression Ferrule	1
32	50057	3/16 Compression Nut	2
33	50058	3/16 Compression Ferrul	2
34	50066	3/16 CP x 1/8 MP	1
35	50061	1/8 Tube - 1/8 FP x 90o	1
36	20153	Copper Tube 3/16 oil gauge	1
37	58024	Lock Nut 8-32 Nylon Z	3
38	50060	3/16 CP x 1/8 FP 90 deg	1
39	60020	Nozzle Assembly Heater Block	1
40	20025	Gauge Mount	1
41	65003	Top Cover - Burner	1
42	20035	Motor Opening Cover	1
43	65012	Retention Head	1

NOZZLE ADAPTER / HEATER BLOCK ASSEMBLY

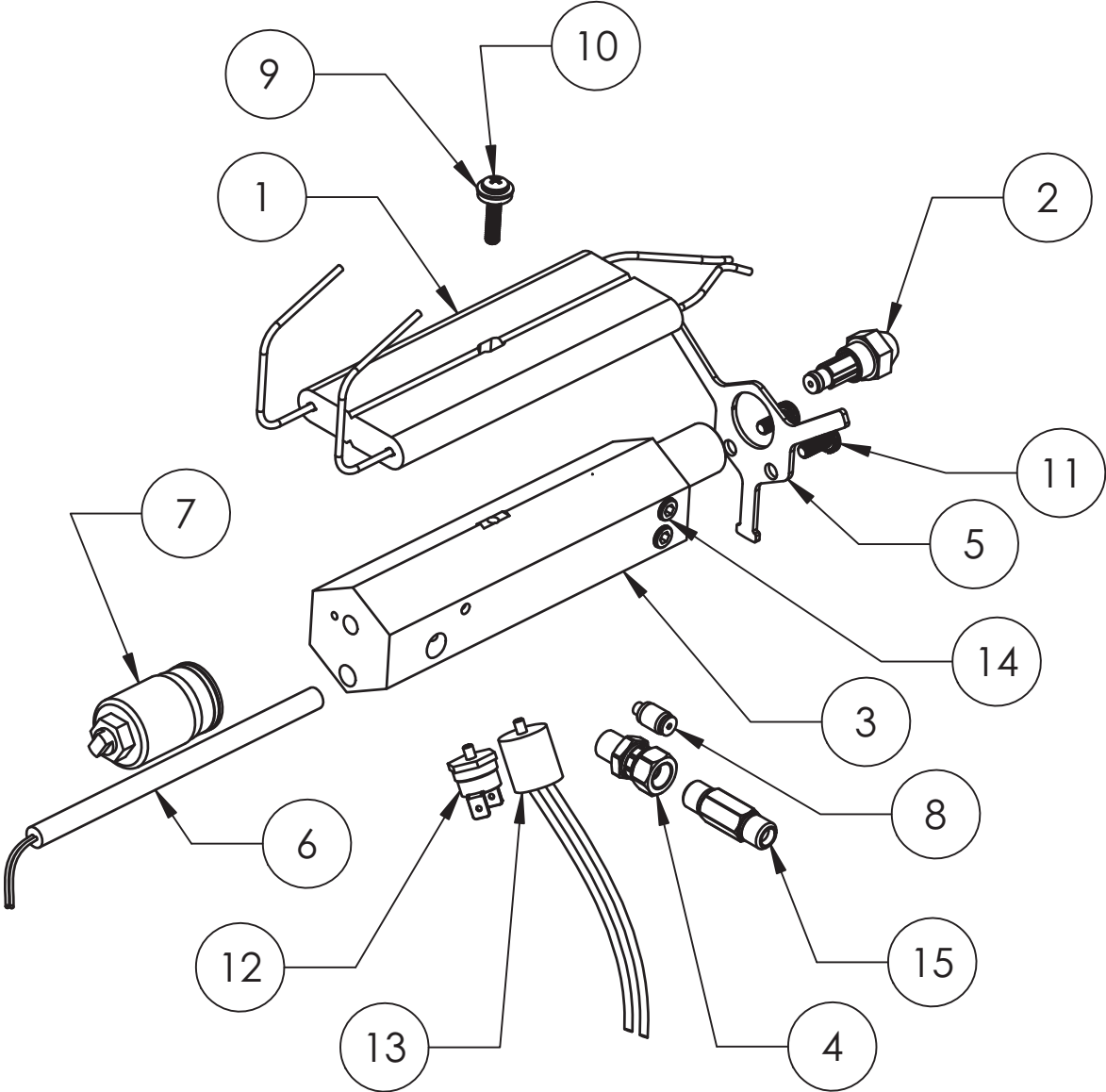

ITEM	PART #	DESCRIPTION	QTY.
	60020*	Nozzle Adapter Heater Block Assembly	
1	30001	Electrode	1
2	40005	9-5 Nozzle	1
3	50009	Nozzle Adapter / Heater Block	1
4	50024	Swivel Fitting	1
5	20008	Nozzle Adaptor Bracket - Three Legs	1
6	30002	Heat Element	1
7	50022	Solenoid Air/Oil 115VAC	1
8	50063	1/8 Tube x 10-32	1
9	58040	Washer Neoprene Bonded, #10 , 1/2" OD	1
10	58045	Pan Head Phillips Mach Screw 10-32 x 7/8 Z	1
11	58016	Machine Screw 10-32 x 1/2 Z Ext Tooth LW	2
12	30003	Thermostat 120F - Proving Switch	1
13	30011	Thermostat 150F - Heater	1
14	50067	Plug - Hex Socket	10
15	50064	1/8 x 1-1/2 Nipple	1

* Does not include items 1,9,10, and 15

MANIFOLD BLOCK ASSEMBLY

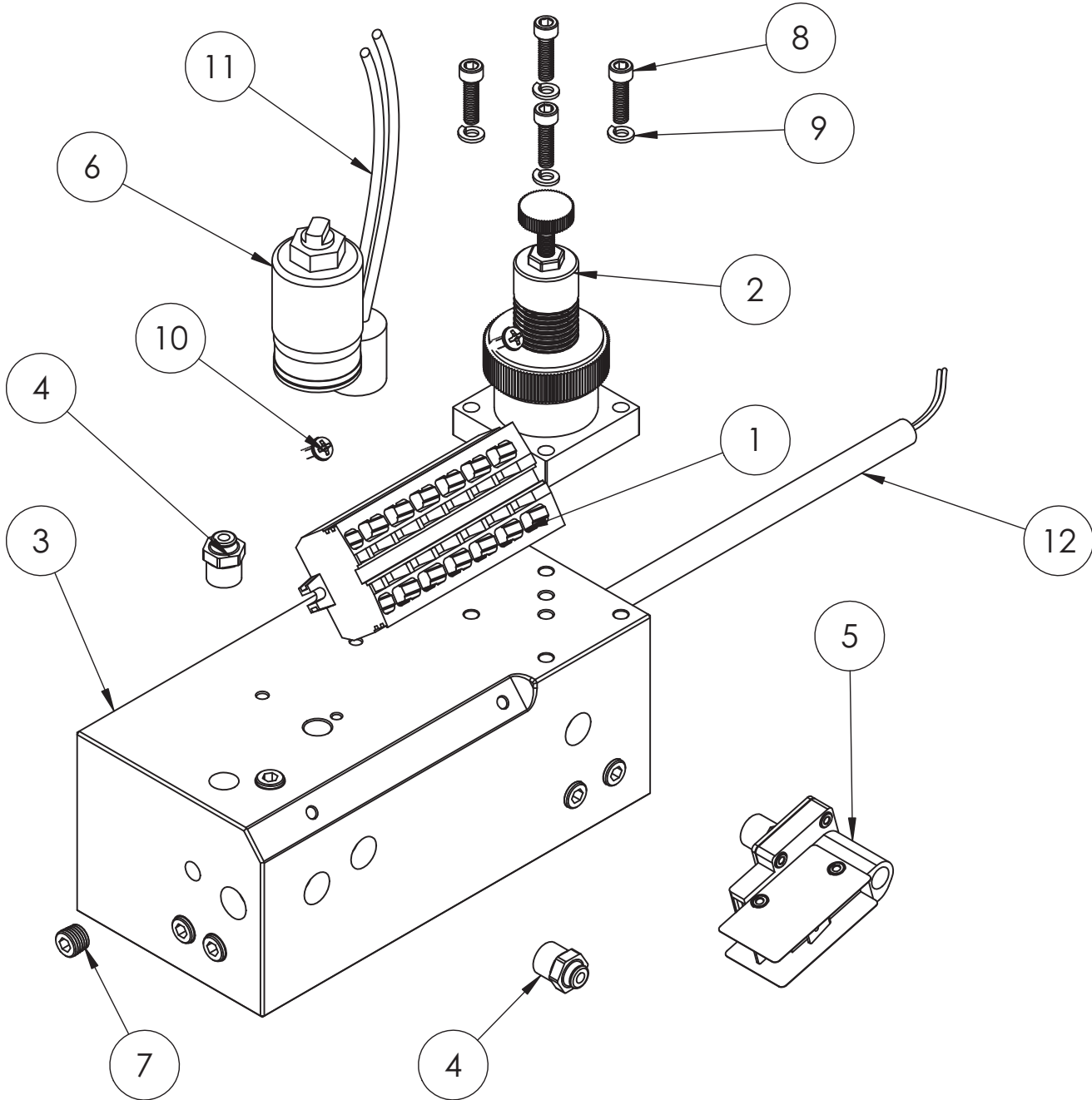

ITEM	PART #	DESCRIPTION	QTY.
1	30010	Terminal Block - Burner	1
2	50021	Regulator- Surface Mount	1
3	50008	Burner Manifold Block	1
4	50062	Tube Fitting 1/8T x 1/8MP	2
5	50054	Air Pressure Switch	1
6	50022	Solenoid Air/Oil 115VAC	1
7	50067	Plug - Hex Socket	12
8	58030	Cap Screw Socket Head 8-32 x 5/8 Black	4
9	58035	Lock Washer #8 Z	4
10	58029	Machine Screw 8-32 x 3/8 Z	2
11*	30011	Thermostat 150F - Heater	1
12*	30002	HEAT ELEMENT	1

* Items 11 and 12 are used in the CE-4 burner only

METERING PUMP ASSEMBLY

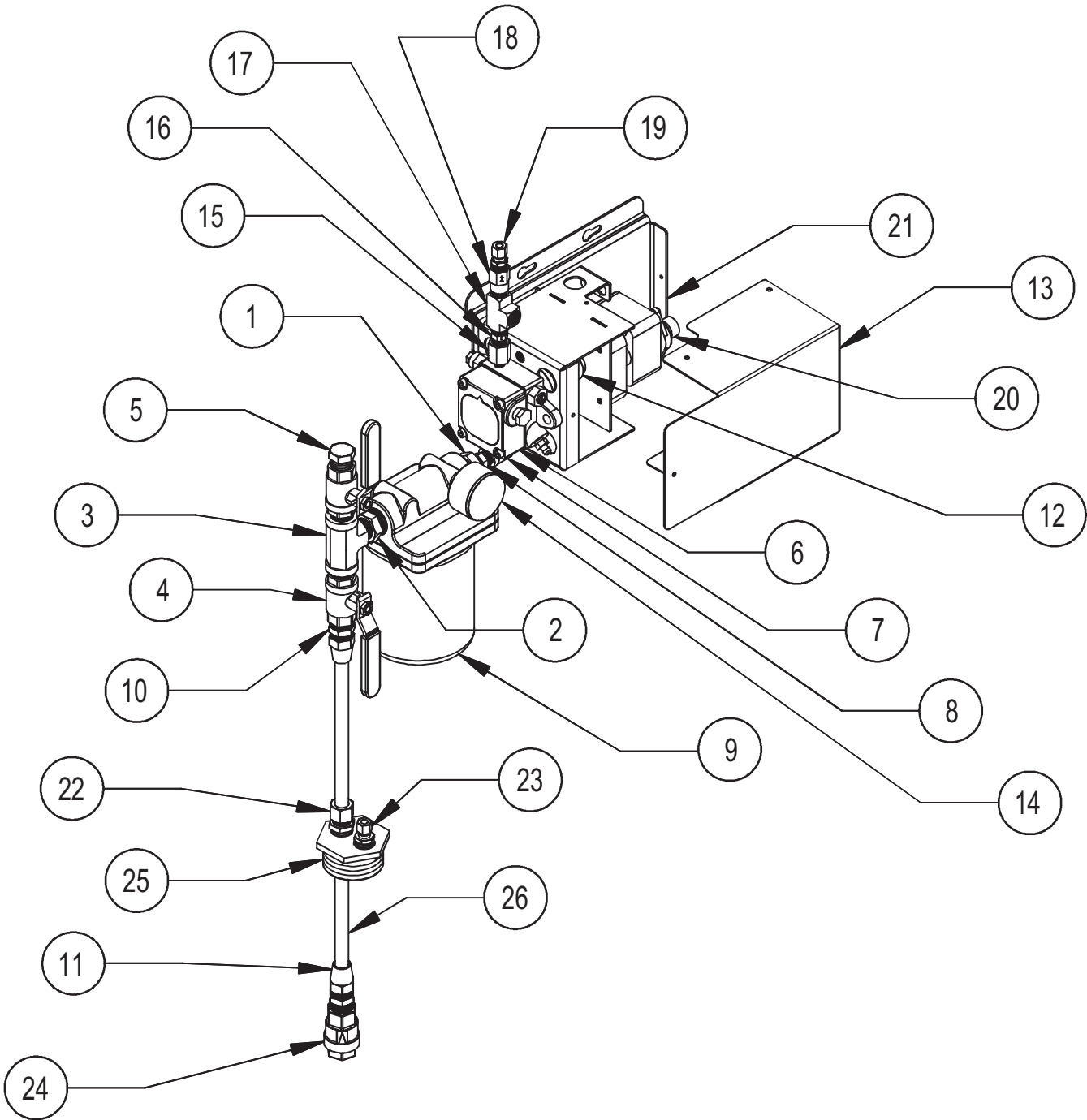

ITEM	PART #	DESCRIPTION	QTY.
	60031	CE 140 Pump Assembly	
	60003	CE 180 Pump Assembly	
	60004	CE 250 Pump Assembly	
	60032	CE 330 Pump Assembly	
	60034	CE 340 Pump Assembly	
1	50030	Bushing 3/4 x 1/4 NPT	1
2	50031	Bushing 3/4 x 1/2 NPT	1
3	50037	Tee 1/2 F x 1/2 F x 1/2 M	1
4	50053	Ball Valve 1/2 NPT	2
5	50038	Plulg 1/2 NPT Hex	1
6	40002	Metering Pump (A2RA-7710)	1
7	50026	ST EL 90~ 1/4 F x 1/4 M	1
8	50028	Nipple 1/4 NPT Hex Plated	1
9	50005	FILTER	1
10	50033	1/2 Flare x 1/2 NPT Brass	2
11	50034	1/2 Flare Nut 45~	2
12	40001	Metering Pump Coupling	1
13	20007	Metering Pump Cover	1
14	50006	GAUGE for FILTER	1
15	50039	1/8 MP x 1/4 FP Plated	1
16	50046	Low Flow Check Valve	1
17	50040	1/4 NPT Tee Brass	1
18	50047	Relief Valve	1
19	50041	1/4 Comp. x 1/4 NPT	1
20	50081	Gearmotor - CE 140	1
20	50080	Gearmotor - CE 180	1
20	50069	Gearmotor - CE 250	1
20	50124	Gearmotor - CE 330	1
20	50200	Gearmotor - CE 340	1
21	60001	Metering Pump Housing WA	1
22	50035	Slip Through Fitting 1/2" MNPT	1
23	50036	1/2" MNPT x 1/4 Comp.	1
24	50070	Foot Valve 1/2"	1
25	50044	Duplex Fitting 2"	1
26	USER SUPPLIED	1/2" Copper Tubing	
	40007	Strainer and Gasket Kit (Pump Head)	
	40008	Screen Element (Lenz Filter)	
	40009	O-Ring (Lenz Filter)	

CE-340 BOILER ASSEMBLY

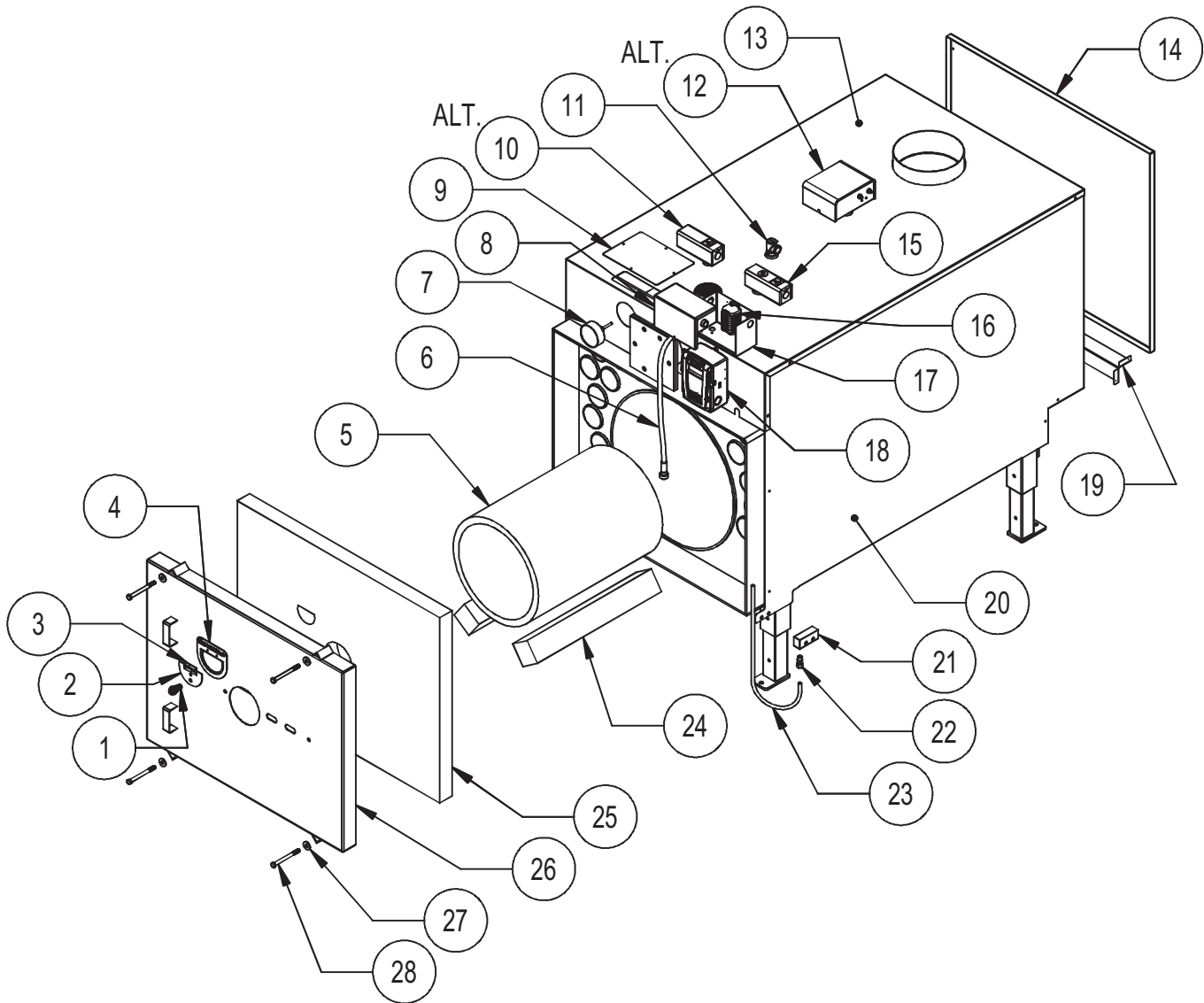

ITEM	PART #	DESCRIPTION	QTY.
	10340	CE 340 Boiler (w/ Burner and Pump)	
	60340	CE 340 Boiler Cabinet Only	
1	50079	Spring Handle	1
2	20080	Observation Port Lid	1
3	50010	Hinge - Observation Port	1
4	20100	Observation Port Ring	1
5	50174	Combustion Sleeve	1
6	30065	Connector Cord - 5 Wire (CE-340 Boiler)	1
7	50189	Gauge - Temp./Press. Boiler	1
8	20010	Electrical Box Lid	1
9	20086	Cover - Shrouding	1
10	50193	Aquastat - Operating (ALTERNATE)	1
11	50197	Relief Valve - Boiler	1
12	50194	Low Water Cut-Off (ALTERNATE)	1
13	20185	Top - Boiler Shrouding	1
14	20186	Back Boiler Shrouding	1
15	50192	HL Aquastat - Manual Reset	1
16	30023	Terminal Block	1
17	20009	Electrical Box	1
18	50191	AquaSmart™ Boiler Control	1
19	20187	Shrouding Brace - Boiler	1
20	20183	Right Side - Boiler Shrouding	1
21	50007	Connector Block - Oil	1
22	50042	Swivel 3/8 Comp 1/4 NPT	1
23	20182	Hookup Tube (CE-340 Boiler)	1
24	50190	Combustion Sleeve Feet	2
25	50201	Insulation CE-340 Boiler Front Door	1
26	85055	Front Door - CE 340 Boiler	1
27	58067	Washer - 1/2" Screw Size	4
28	58066	HHCS 1/2 - 13 X 6	4
	20184	Left Side - Boiler Shrouding	1

Through the Wall Chimney Installation:

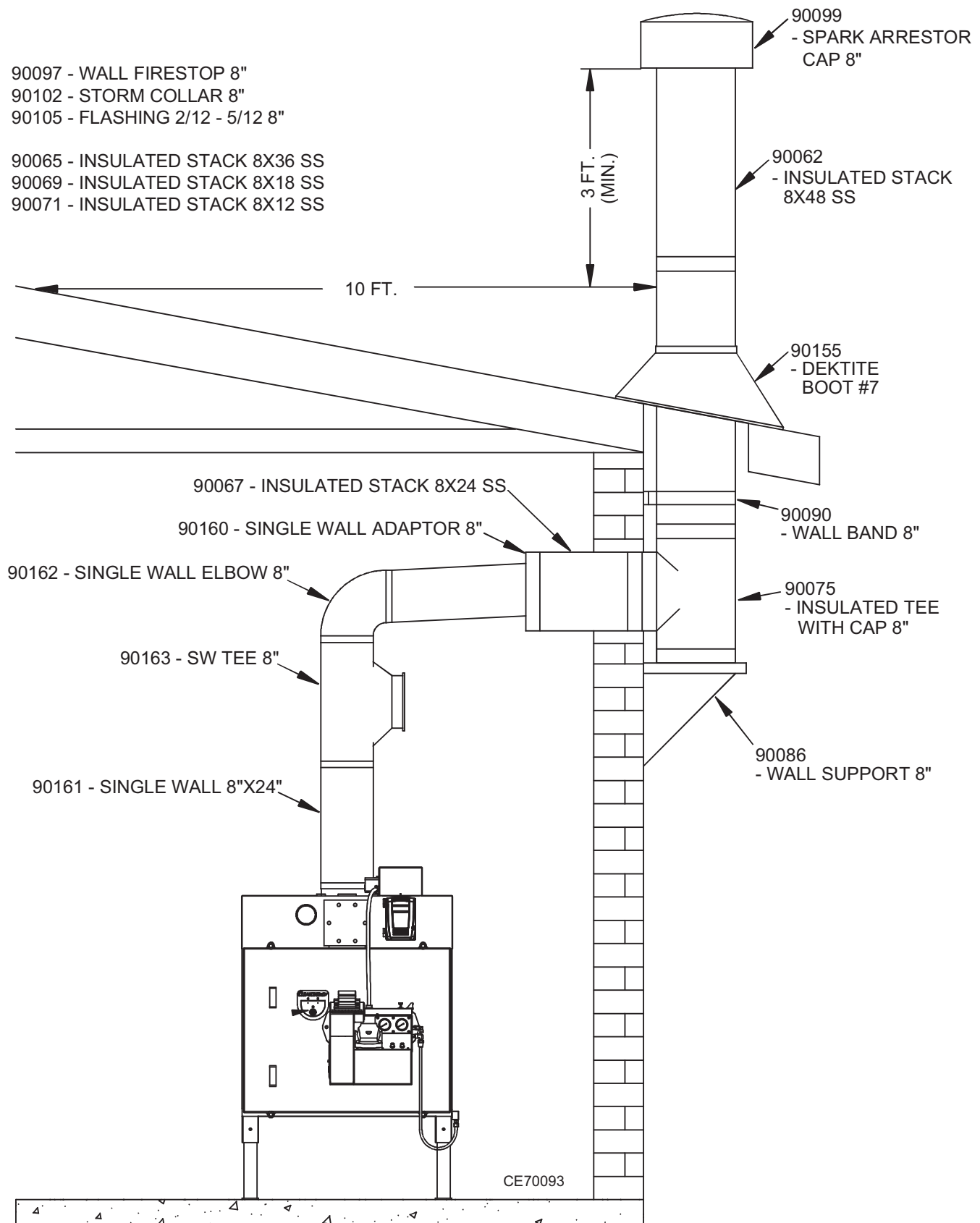

Through the Roof Chimney Installation:

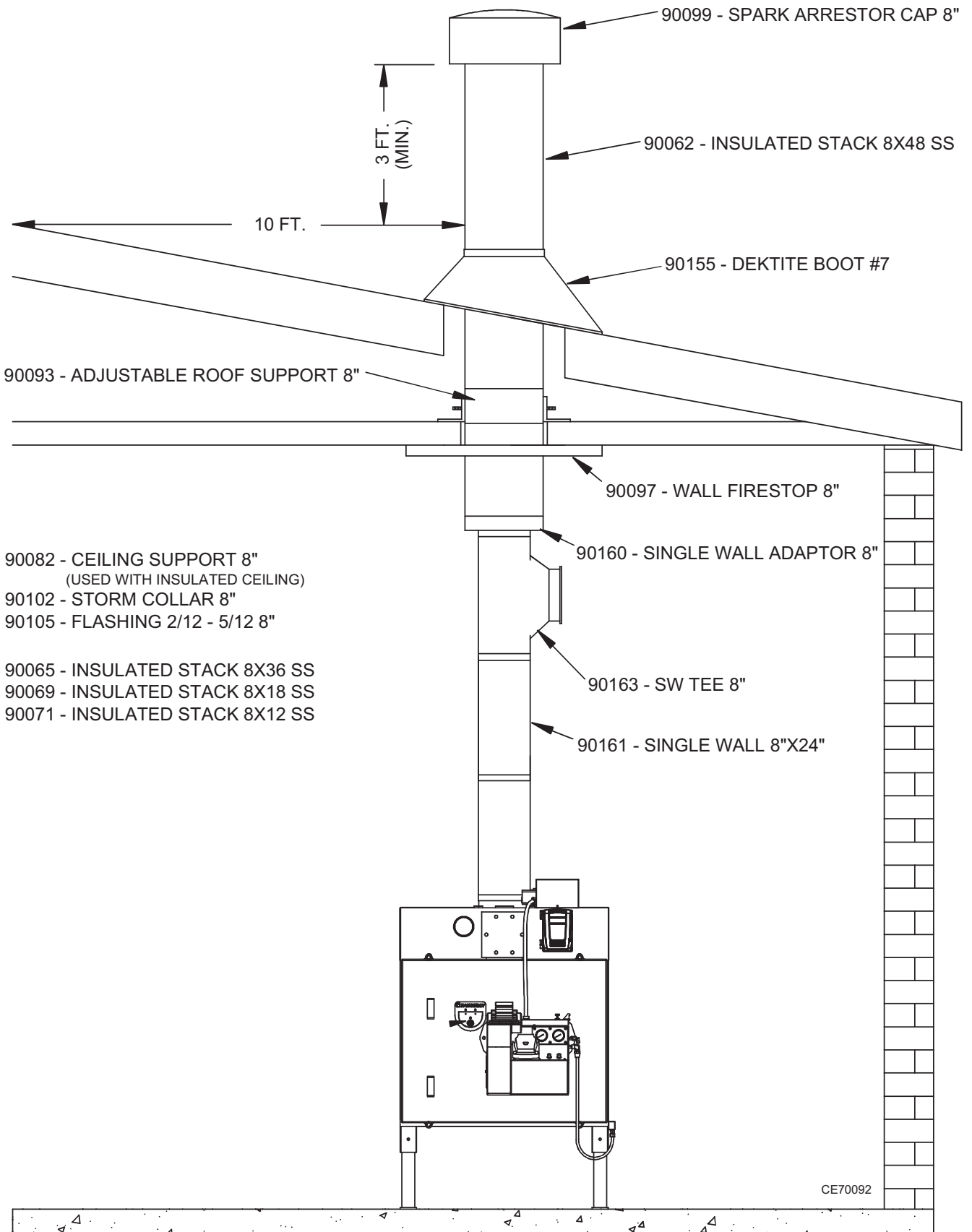

APPENDIX A

ALTERNATE Temperature Operating Control and Low Water Cut-Off:

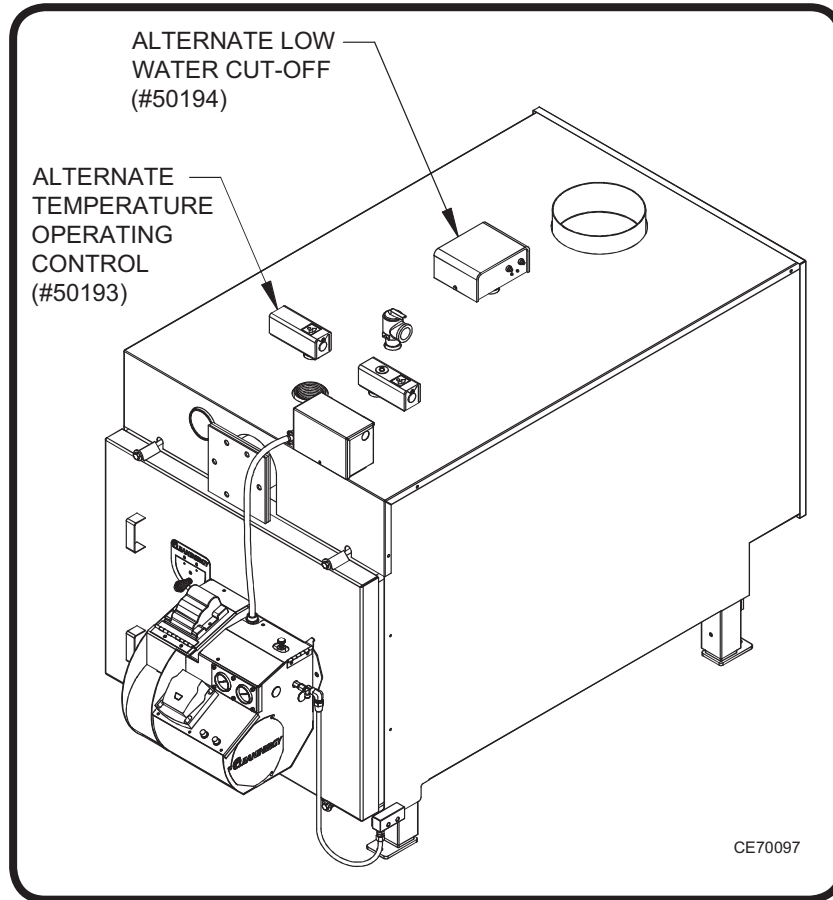

ALTERNATE CE-340 Boiler Cabinet Wire Diagram:

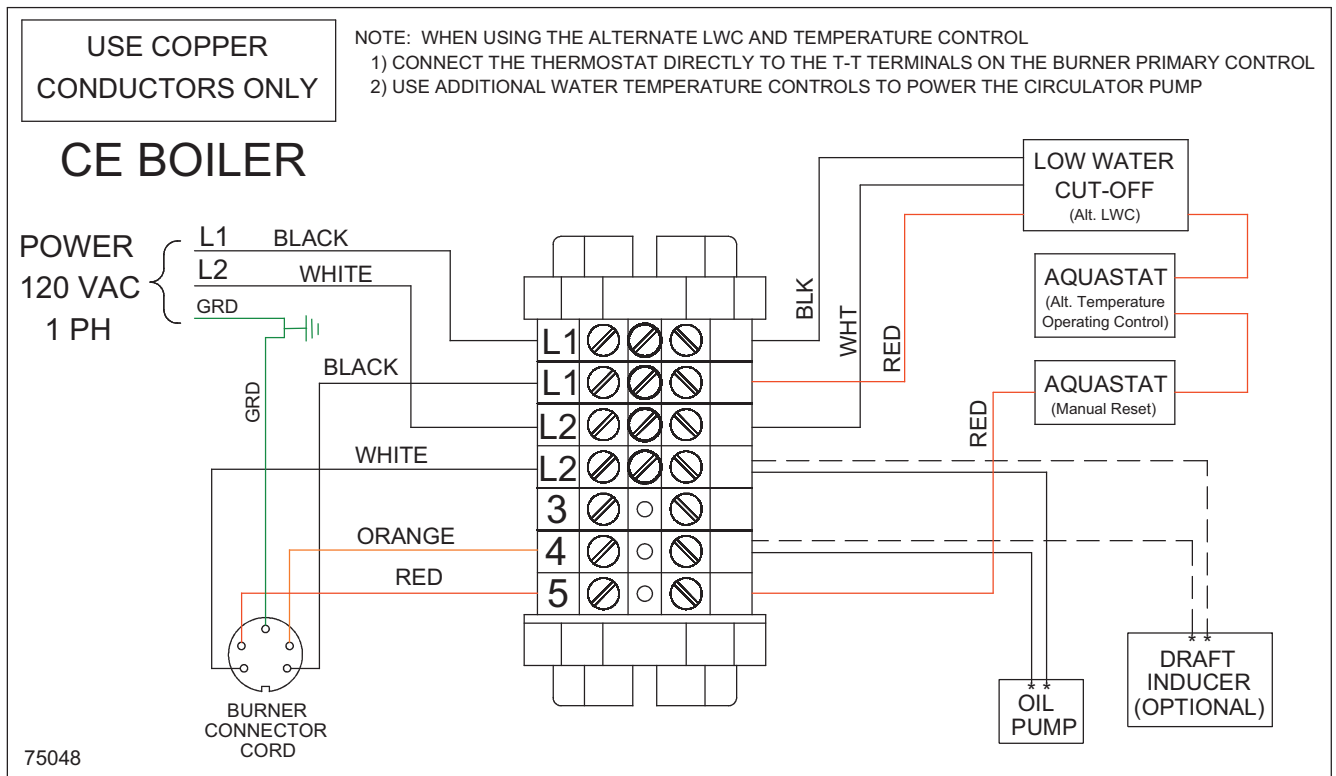

APPENDIX A

Domestic Hot Water Coil Installation:



DANGER: Mixing valves must be used to supply domestic hot water at a safe temperature. Mixing valves are not intended to be the only scalding safe-guard.

- (1) Refer to Figure A2.
- (2) Remove the six nuts and bolts holding the cover in position.
- (3) Carefully slide the domestic hot water coil, with the rubber gasket in place, into the tube.
- (4) Tighten the hot water coil in position with the six nuts and bolts.

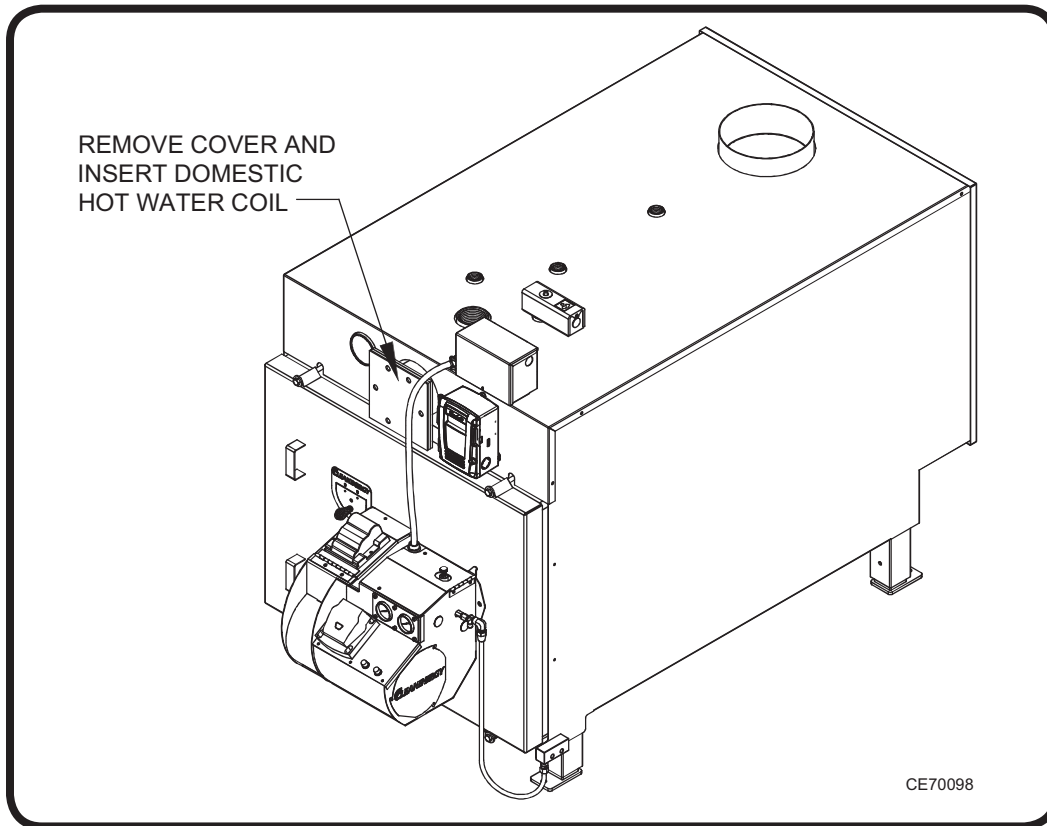

Figure A2: Domestic Hot Water Coil Location

Ten Year Combustion Chamber/Heat Exchanger Warranty

ONE YEAR Parts Warranty

Clean Energy Heating Systems LLC, MANUFACTURER, hereby warrants the MANUFACTURER'S product to be free from defects in material and workmanship under normal use and conditions as set forth in the provisions and limitations below. The warranty extends to the original owner whose name appears on the Warranty Registration Card returned to MANUFACTURER.

TEN YEAR COMBUSTION CHAMBER / HEAT EXCHANGER WARRANTY

The ten year warranty on the combustion chamber / heat exchanger shall be from the date of purchase by the original purchaser and shall be subject to the prorated schedule of years listed in the table below

0 to 5 years	Repair or replace FREE of charge
6 to 10 years	Repair or replace shared cost 50/50

All labor and transportation costs are the responsibility of the owner. Repair or replacement shall be determined by MANUFACTURER. Photos or returned goods at owner's expense may be required for warranty determination.

ONE YEAR PARTS WARRANTY

All component parts are covered under warranty for a period of ONE YEAR from the date of purchase. Owner is responsible for all labor and transportation costs associated with warranty claims.

CONDITIONS AND LIMITATIONS:

- A. The owner must complete and return the Warranty Registration Card within thirty (30) days of purchase to activate Warranty Coverage.
- B. The equipment must be fired at rated capacity only with fuels listed on data label.
- C. The equipment must be installed, operated, and maintained in accordance with Federal, State, and Local regulations as well as with all MANUFACTURER'S installation and operating instructions.
- D. The equipment must not be installed in any corrosive atmosphere environment.
- E. No parts or controls may be modified, altered, or by-passed.
- F. MANUFACTURER shall not be responsible for any failure due to an Act of God.
- G. MANUFACTURER is not responsible for additions or changes made by a dealer or distributor that goes beyond the terms of this Limited Warranty.

Clean Energy Heating Systems, LLC assumes no liability for consequent damage of any kind, and by acceptance of this equipment the purchaser assumes all liability for the consequence of its use or misuse by the purchaser or others.



CLEAN ENERGY HEATING SYSTEMS, LLC
WARRANTY CARD

(PLEASE PRINT CLEARLY)

FIRST NAME _____ LAST NAME _____

COMPANY NAME _____

STREET _____ CITY _____ STATE _____ ZIP CODE _____

TELEPHONE _____ EMAIL _____ DATE OF PURCHASE: _____

BOILER MODEL:

CE-340

BURNER MODEL:

CE-4

BURNER SERIAL NO. _____

BOILER SERIAL NO. _____

WITHIN 30 DAYS OF PURCHASE RETURN WARRANTY CARD TO: CLEAN ENERGY HEATING SYSTEMS LLC
540 MAPLE STREET
HONEY BROOK PA USA 19344



Approved Method to Dispose of Waste Oil

Sold and Serviced by:

NAME:

ADDRESS:

TELEPHONE #:

PLACE
STAMP
HERE

CLEAN ENERGY HEATING SYSTEMS LLC
540 MAPLE STREET
HONEY BROOK PA USA 19344